

Form 8024
August, 1912

PRICE LIST

OF

PARTS



MACHINES
Nos. 92-1 and 92-2

THE SINGER MANUFACTURING COMPANY

From the library of: Diamond Needle Corp

INDEX

	PAGE
ACCESSORIES	21
HEMMER	21
IRON BASE	21
MACHINE NO. 92-1.....	7
" " 92-2.....	14
NUMERICAL LIST OF PARTS.....	29
OBSOLETE PARTS	27
THREAD UNWINDER.....	22
UNDER DRIVER (BALL BEARING)	24
" " (OIL CONTROLLING PULLEY).....	23

From the library of: Diamond Needle Corp

INSTRUCTIONS FOR ORDERING

In ordering from this list, use ONLY the PART number in the FIRST column.

The number stamped on a Sewing Machine part is in every case the number of the single part only.

Every combination of parts sent out as such has its specific number, which, although not stamped on the parts, must be used when ordering the combination.

Each number always indicates the SAME PART in whatever list it appears, or for whatever machine.

The letters after some of the numbers indicate the style of finish only, as follows: -

- A. Hardened, Polished and Plated.
- B. Polished and Plated.
- C. Hardened only.
- D. Polished only.
- E. Soft, not Polished.
- F. Hardened and Polished.
- H. Blued.

These letters MUST BE USED when they appear in the list, and AFTER the number as in the list.

In this series

- 1 to 1500 and 50001 to 51500 are Screw Numbers.
- 1501 to 1800 are Nut Numbers.
- 1801 to 2000 are Roller Numbers.
- 2001 to 50000 are numbers of Machine Parts.

The figures in the second column refer only to the plates, illustrating the parts, and are NOT TO BE USED in ordering.

Parts marked with an asterisk (*) are furnished only when repairs are made at factory.

LIST OF PARTS COMPLETE FOR MACHINE NO. 92-1

FOR BAG WORK. HAS ONE NEEDLE, ONE LOOPER, DROP FEED AND FLAT PRESSER BAR SPRING

NO.	PLATE	NAME	EACH
*49001	---	Arm, upper and lower (solid).....	\$30 00
18130	6178	" Oil Tube with 29599, for front bearing.....	06
18130	6178	Arm Oil Tube with 29599, for intermediate bearing.....	06
11119	6178	Arm Oil Tube with 29599, for oiling 49101.....	06
12454	6178	Arm Oil Tube with 29599, for oiling 49049.....	06
49091	6178	Arm Oil Tube with 49092, for oiling 49108.....	20
29599	6178	Arm Oil Tube Packing (felt) for 11119, 12454 and 18130.....	per 100 25
49092	6178	Arm Oil Tube Packing (felt) for 49091..	01
49135	6176	" Rock Shaft.....	75
49003	6177	" " " Bushing (back).....	85 25
446c	6177	" " " " " Set Screw.....	03
49004	6177	Arm Rock Shaft Bushing (intermediate)	35 25
446c	6177	" " " " " Set Screw.....	03
49006	6177	Arm Rock Shaft Collar with two 443c..	30
443c	6177	" " " " Set Screw.....	03
49104	6177	" " " Crank (back) with 1036c and 50083c.....	1 50
50083c	6177	Arm Rock Shaft Crank (back) Position Screw.....	05
1036c	6177	Arm Rock Shaft Crank (back) Set Screw	03
49008	6177	" " " " (front) with two 50084c.....	1 00
50084c	6177	Arm Rock Shaft Crank (front) Position Screw.....	04
50084c	6177	Arm Rock Shaft Crank (front) Set Screw	04
49005	6177	" " " Flanged Bushing (front)	50
430c	6177	" " " " " " " Set Screw.....	04

Library of Diagon Needle Corp

NO.	PLATE	NAME	EACH
49084	6181	Arm Rock Shaft Oil Cover.....	\$ 10
193D	6181	" " " " " Screw.....	03
49097	6176	" Rotary Shaft.....	2 50
49011	6181	" " " Bushing (front).....	35
430C	6181	" " " " " Set Screw.....	04
49010	6177	Arm Rotary Shaft Collar with two 1259C	30
1259C	6177	" " " " Set Screw.....	03
49012	6179	" " " Flanged Bushing (back).....	1 50
49093	6178	Arm Rotary Shaft Flanged Bushing (back) Oil Pad, long (braided cotton)	02
49013	6178	Arm Rotary Shaft Flanged Bushing (back) Oil Pad, short (braided cotton)	01
159F	6198	Arm Rotary Shaft Flanged Bushing (back) Screw.....	03
49014	6181	Arm Rotary Shaft Flanged Bushing (intermediate).....	50
448C	6181	Arm Rotary Shaft Flanged Bushing (intermediate) Set Screw.....	03
18144	6178	Arm Rotary Shaft Oil Pad (felt).....	01
144D	6198	" " " Screw.....	08
4288H	6179	" Side Cover (lower).....	10
286D	6198	" " " " Thumb Screw...	10
4288H	6179	" " " (upper).....	10
286D	6198	" " " " Thumb Screw...	10
23873	6175	Balance Wheel with two 430C.....	80
430C	6177	" " Set Screw.....	04
49106	6175	Cloth Plate.....	2-00 1 75
50085F	6198	" " Screw.....	08
49016H	—	" " Slide.....	30
49017H	6179	Cloth Plate Slide complete, Nos. 38419, 49016H and two 725H.....	40-20
38419	6181	Cloth Plate Slide Spring.....	05
725H	6181	" " " " Screw.....	02
49107	—	Cloth Plate complete, Nos. 49017H, 49053, 49054, 49106, 49116 and two 226D.....	4-65 3 20
49108	6176	Crank Connecting Rod with 896E, 49099, 49109 and two 145E.....	2-00 15 0
896E	6180	Crank Connecting Rod Adjusting Screw	04
49109	6181	" " " " Washer	01
*49099	—	" " " Cap.....	—
145E	6198	" " " " Screw.....	04
50147C	6198	" " " Hinge Screw.....	20
1513E	6198	" " " " Nut	05
49020H	6179	Face Plate.....	75
193F	6181	" " Screw.....	03

NO.	PLATE	NAME	EACH
49021	6180	Feed Bar with 220D and 457C.....	\$2-50 1 75
49022	6180	" " Hinge Pin.....	10
457C	6180	" " " " Set Screw.....	02
49023	6180	" Connecting Rod with 2653, 4784, 49024 and two 896E.....	1 00
*49024	—	Feed Connecting Rod Cap.....	—
896E	6180	" " " " Screw.....	04
4784	6180	" " " Oil Pad (felt).....	01
2653	6180	" " " " " Pin.....	01
49025	6182	" Dog, for large bags.....	1-00 5 0
49081	6183	" " " small bags.....	75
49103	6182	" " (spiked teeth) for clay-filled bags.....	1-00
49125	6184	Feed Dog (double).....	1-50
172C	6194	" " Screw.....	04
220D	6180	" " Stop Screw.....	02
49026	6180	" Eccentric (cast iron) with two 1259C.....	1 00
1259C	6180	Feed Eccentric Set Screw.....	03
49027	6180	" Lifting Eccentric (cast iron) with two 1259C.....	1-00
49028	6180	Feed Lifting Eccentric Connection with 457C, 2653, 4784, 49029 and two 1057E	1-50 1 75
*49029	—	Feed Lifting Eccentric Connection Cap	—
1057E	6180	" " " " " Screw.....	04
49030	6180	Feed Lifting Eccentric Connection Hinge Pin.....	10
457C	6180	Feed Lifting Eccentric Connection Hinge Pin Set Screw.....	02
4784	6180	Feed Lifting Eccentric Connection Oil Pad (felt).....	01
2653	6180	Feed Lifting Eccentric Connection Oil Pad Pin.....	01
1259C	6180	Feed Lifting Eccentric Set Screw.....	03
50086C	6181	" Regulating Screw Stud.....	22
1714C	6181	" " " " Nut.....	04
49031	6181	" " " " Sleeve.....	50
49032	6181	" " " " Washer.....	05
49033	6179	" Rock Shaft.....	1 00
49034	—	Feed Rock Shaft complete, Nos. 49033 and 49035.....	2-50 1 75
49035	6179	Feed Rock Shaft Crank with two 896E.	1-50
896E	6180	" " " " Clamping Screw	04
11398	6179	" " " Hinge Pin.....	75
1508E	6198	" " " " " Nut.....	06
622C	6198	" " " " " Screw Bear- ing.....	12

NO.	PLATE	NAME	EACH
1508E	6198	Feed Rock Shaft Hinge Pin Screw	
		Bearing Nut.....	\$ 06
27398	6181	Feed Rock Shaft Washer.....	10 05
36421	6200	Guide.....	15
	194D 6200	" Screw Stud.....	02
	671D 6200	" Thumb Screw.....	10
49036	6192	Looper (double thread) with 590D and 49080.....	2-25 25
49037	6192	Looper (single thread).....	2-25 25
49038	6176	" Bell Crank with 4784.....	2-50 2 00
49039	6176	" " " Hinge Stud.....	60
	448C 6181	" " " " " S e t Screw.....	03
	4784 6180	Looper Bell Crank Oil Pad (felt).....	01
49040	6176	" " " Pitman with 175E, 49041, 49042 and three 171E.....	2-00 1 15
50070C	6192	Looper Bell Crank Pitman Ball Screw Stud (lower).....	15
1636E	6198	Looper Bell Crank Pitman Ball Screw Stud (lower) Nut.....	03
50070C	6192	Looper Bell Crank Pitman Ball Screw Stud (upper).....	15
1636E	6198	Looper Bell Crank Pitman Ball Screw Stud (upper) Nut.....	03
*49041	—	Looper Bell Crank Pitman Cap (lower)	—
	171E 6192	" " " " " " " Screw.....	03
*49042	—	Looper Bell Crank Pitman Cap (upper)	—
	171E 6192	" " " " " " " Screw (long).....	03
	175E 6192	Looper Bell Crank Pitman Cap (upper) Screw (short).....	02
49043	6192	Looper Bell Crank Pitman Washer (fibre).....	02
49044	6192	Looper Carrier with 4784 and two each 175D and 1147C.....	2-50 1 00
	175D 6192	Looper Carrier Clamping Screw.....	02
38440	6192	" " Hinge Pin.....	20
	1147C 6192	" " " " Set Screw.....	03
	4784 6192	" " Oil Pad (felt).....	01
49045	6192	Looper Carrier Pitman complete, Nos. 1708E, 1709E, 49046, 49088 and 49089	3 25
50070C	6192	Looper Carrier Pitman Ball Screw Stud (right).....	15
	1519E 6192	Looper Carrier Pitman Ball Screw Stud (right) Nut.....	03
46237	6192	Looper Carrier Pitman Ball Stud (left)	25
	1147C 6192	" " " " " " Set Screw.....	03

NO.	PLATE	NAME	EACH
*49085	—	Looper Carrier Pitman Cap (left).....	\$ —
	171E 6192	" " " " " Screw	03
*49085	—	" " " " (right).....	—
	171E 6192	" " " " " Screw	03
*49086	—	" " " End B e a r i n g (left).....	—
*49087	—	Looper Carrier Pitman End Bearing (right).....	—
49088	—	Looper Carrier Pitman Head (left) Nos. 46237, 49085, 49086 and two 171E...	1 50
49089	—	Looper Carrier Pitman Head (right) Nos. 49085, 49087, 50070C and two 171E...	1 50
49046	6192	Looper Carrier Pitman Rod.....	10
	1708E 6192	" " " " Nut (left)...	03
	1709E 6192	" " " " " (right)	03
49043	6192	" " " Washer (fibre)...	02
49047	6193	" " Rock Shaft.....	50
11411	6193	" " " " Collar with 453C.....	10
	453C 6193	Looper Carrier Rock Shaft Collar Set Screw.....	02
49048	6193	Looper Carrier Rock Shaft Crank (back) forked, with 50083C.....	2-00 1 25
50083C	6193	Looper Carrier Rock Shaft Crank (back) Set Screw.....	05
49049	6193	Looper Carrier Rock Shaft Crank (back) Slide Block.....	1 50
49050	6193	Looper Carrier Rock Shaft Crank (front) with 1147C and two 1253C.....	75
	1253C 6193	Looper Carrier Rock Shaft Crank (front) Set Screw.....	03
49051	6193	Looper Eccentric (cast iron) with two 1259C.....	4-00 3 50
	1259C 6193	Looper Eccentric Set Screw.....	03
49116	6175	" Gate with 453C.....	1 00
49053	6181	" " Hinge Pin.....	10
	453C 6181	" " " " Set Screw.....	02
49054	6181	" " Lock Spring.....	10
	226D 6181	" " " " Screw.....	02
	1147C 6193	" Set Screw.....	03
49080	6192	" Thread Guard.....	10
	590D 6192	" " " Screw.....	02
49055	6194	Needle Bar (hollow).....	75
49056	6194	" " Bushing (lower).....	50 2 50
	435C 6194	" " " " Set Screw..	04
49056	6194	" " " (upper).....	50 2 50
	1133E 6194	" " " " Set Screw..	02

PARTS FOR MACHINE NO. 92-1

NO.	PLATE	NAME	EACH
49101	6194	Needle Bar Connecting Link	\$ 75
49057	6194	" " " Hinge Stud	50
1517E	6194	" " " " "	
		Nut	04
49058	6194	Needle Bar Connecting Stud with 391E	50
391E	6194	" " " " Clamping	
		Screw	02
1629C	6194	Needle Clamping Nut	08
49059	6195	Presser Bar	40
49060	6195	" " Bushing (lower)	80 90
435C	6195	" " " " Set Screw	04
49061	6195	" " " (upper)	50 50
1133E	6195	" " " " Set Screw	02
49062	6195	" " Lifter	75 75
212D	6195	" " " Cap Screw	04
49063	6195	" " " Friction Washer	02
49064	6195	" " " Hinge Stud	25
453C	6195	" " " " Set Screw	02
49065	6195	" " Lifting Bracket with 453C and 892F	1 25
892F	6195	Presser Bar Lifting Bracket Adjusting Screw	05
453C	6195	Presser Bar Lifting Bracket Set Screw	02
49066	6195	" " " Link	25
212D	6195	" " " " Cap Screw	04
724D	6195	" " " " Hinge Screw	05
49067	6179	" " Spring (flat)	50
38468	6195	" " " Stud	03
49082	6183	" Foot for 49081	1 00
50087F	6198	" " Hinge Screw	06
49068	—	" " Plate	1 00
49069	—	" " Shank	75
49070	6182	Presser Foot (hinged) complete for 49025 and 49103, Nos. 49068, 49069 and 50087F	1-75 80
50087F	6198	Presser Foot Hinge Screw	06 06
49126	—	" " Plate	1-00 05
49127	—	" " Shank	75 60
49128	6184	Presser Foot (hinged) complete for 49125, Nos. 49126, 49127 and 50087F	1-75 80
190D	6198	Presser Foot Screw	03
574D	6198	Pressure Regulating Thumb Screw	15
1539D	6198	" " " " Lock	
		Nut	05
2102	6194	Tension (under thread) Disc	05
1560C	6194	" " " " Regulating Thumb Nut	04

PARTS FOR MACHINE NO. 92-1

NO.	PLATE	NAME	EACH
916F	6194	Tension (under thread) Screw Stud	\$ 08
10148	6194	" " " Spring	03
17547	6194	" " " Thread Guide	25
2102	6194	" (upper thread) Disc	05
1560C	6194	" " " " Regulating Thumb Nut	04
916F	6194	Tension (upper thread) Screw Stud	08
13710	6194	" " " Spring	03
17547	6194	" " " Thread Guide	25
49071	6194	Thread (under) Eyelet	10
172F	6194	" " " Screw	04
49072	6196	" " Take-up	30
190D	6196	" " " Screw	03
49073	6196	" (upper) Controller	75
974F	6196	" " " Hinge Screw	06
914F	6196	" " " " Screw	04
39541	6196	" " " " Washer	05
49075	6196	" " Take-up with 457C	80
457C	6196	" " " Set Screw	02
49129	6184	Throat Plate, for double thread, for 49125	1-25
49130	6184	Throat Plate with 665D and 49078, for single thread, for 49125	1-75
49131	6182	Throat Plate, for double thread, for 49025 and 49103	1-00
49132	6182	Throat Plate with 665D and 49078, for single thread, for 49025 and 49103	1-50
49133	6183	Throat Plate, for double thread, for 49081	1-00
49134	6183	Throat Plate with 665D and 49078, for single thread, for 49081	1-50
691F	6198	Throat Plate Screw	04
49078	6181	" " Thread Retainer	15
665D	6181	" " " " Screw	02

From the library of Diamond Needle Corp

**LIST OF PARTS COMPLETE
FOR
MACHINE NO. 92-2**

**FOR BAG WORK, HAS ONE NEEDLE, ONE LOOPER, DROP FEED,
MAKES STITCH FROM ¼ INCH TO ½ INCH LONG,
FLAT PRESSER BAR SPRING**

NO	PLATE	NAME	EACH
*49001	—	Arm, upper and lower (solid).....	\$30 00
18130	6178	" Oil Tube with 29599, for front bearing.....	06
18130	6178	Arm Oil Tube with 29599, for intermediate bearing.....	06
11119	6178	Arm Oil Tube with 29599, for oiling 49101.....	06
12454	6178	Arm Oil Tube with 29599, for oiling 49049.....	06
49091	6178	Arm Oil Tube with 49092, for oiling 49108.....	20
29599	6178	Arm Oil Tube Packing (felt) for 11119, 12454 and 18130..... per 100	25
49092	6178	Arm Oil Tube Packing (felt) for 49091..	01
49135	6176	" Rock Shaft.....	75
49003	6177	" " " Bushing (back).....	85 75
446C	6177	" " " " " Set Screw.....	03
49004	6177	Arm Rock Shaft Bushing (intermediate)	85 75
446C	6177	" " " " " " Set Screw.....	03
49006	6177	Arm Rock Shaft Collar with two 443C..	30
443C	6177	" " " " " Set Screw.....	03
49104	6177	" " " Crank (back) with 1036C and 50083C.....	1 50
50083C	6177	Arm Rock Shaft Crank (back) Position Screw.....	05
1036C	6177	Arm Rock Shaft Crank (back) Set Screw.	03
49008	6177	" " " " (front) with two 50084C.....	1 00
50084C	6177	Arm Rock Shaft Crank (front) Position Screw.....	04
50084C	6177	Arm Rock Shaft Crank (front) Set Screw	04
49005	6177	" " " Flanged Bushing (front)	50
430C	6177	" " " " " " Set Screw.....	04

PARTS FOR MACHINE NO. 92-2

NO.	PLATE	NAME	EACH
49084	6181	Arm Rock Shaft Oil Cover.....	\$ 10
193D	6181	" " " " " Screw.....	03
49105	6176	" Rotary Shaft.....	2 50
49011	6181	" " " Bushing (front).....	35
430C	6181	" " " " " Set Screw.....	04
49010	6177	Arm Rotary Shaft Collar with two 1259C	30
1259C	6177	" " " " " Set Screw.....	03
49012	6179	" " " Flanged Bushing (back).....	1 50
49093	6178	Arm Rotary Shaft Flanged Bushing (back) Oil Pad, long (braided cotton)	02
49013	6178	Arm Rotary Shaft Flanged Bushing (back) Oil Pad, short (braided cotton)	01
159F	6198	Arm Rotary Shaft Flanged Bushing (back) Screw.....	03
49014	6181	Arm Rotary Shaft Flanged Bushing (intermediate).....	50
448C	6181	Arm Rotary Shaft Flanged Bushing (intermediate) Set Screw.....	03
18144	6178	Arm Rotary Shaft Oil Pad (felt).....	01
144D	6198	" " " " " Screw.....	08
4288H	6179	" Side Cover (lower).....	10
286D	6198	" " " " " Thumb Screw...	10
4288H	6179	" " " (upper).....	10
286D	6198	" " " " " Thumb Screw..	10
23873	6175	Balance Wheel with two 430C.....	80
430C	6177	" " " " " Set Screw.....	04
49106	6175	Cloth Plate.....	8-00 175
50085F	6198	" " " " " Screw.....	08
49016H	—	" " " " " Slide.....	30
49017H	6179	Cloth Plate Slide complete, Nos. 38419, 49016H and two 725H.....	40 75
38419	6181	Cloth Plate Slide Spring.....	05
725H	6181	" " " " " Screw.....	02
49107	—	Cloth Plate complete, Nos. 49017H, 49053, 49054, 49106, 49116 and two 226D.....	4-85 3 75
49108	6176	Crank Connecting Rod with 896E, 49099, 49109 and two 145E.....	2-00 1 75
896E	6180	Crank Connecting Rod Adjusting Screw	04
49109	6181	" " " " " Washer	01
*49099	—	" " " " " Cap.....	—
145E	6198	" " " " " Screw.....	04
50147C	6198	" " " " " Hinge Screw.....	20
1513E	6198	" " " " " Nut	05
49020H	6179	Face Plate.....	75
193F	6181	" " " " " Screw.....	03

NO.	PLATE	NAME	EACH
*49085	---	Looper Carrier Pitman Cap (left).....	\$ ---
171E	6192	" " " " " Screw.	03
*49085	---	" " " " (right).....	---
171E	6192	" " " " " Screw	03
*49086	---	" " " " End Bearing (left).....	---
*49087	---	Looper Carrier Pitman End Bearing (right).....	---
49088	---	Looper Carrier Pitman Head (left) Nos. 46237, 49085, 49086 and two 171E..	1 50
49089	---	Looper Carrier Pitman Head (right) Nos. 49085, 49087, 50070c and two 171E..	1 50
49046	6192	Looper Carrier Pitman Rod.....	10
1708E	6192	" " " " Nut (left)...	03
1709E	6192	" " " " " (right)	03
49043	6192	" " " Washer (fibre)..	02
49047	6193	" " Rock Shaft.....	50
11411	6193	" " " " Collar with 453c.....	10
453c	6193	Looper Carrier Rock Shaft Collar Set Screw.....	02
49048	6193	Looper Carrier Rock Shaft Crank (back) forked, with 50083c.....	2-00 12 5
50083c	6193	Looper Carrier Rock Shaft Crank (back) Set Screw.....	05
49049	6193	Looper Carrier Rock Shaft Crank (back) Slide Block.....	1 50
49050	6193	Looper Carrier Rock Shaft Crank (front) with 1147c and two 1253c.....	75
1253c	6193	Looper Carrier Rock Shaft Crank (front) Set Screw.....	03
49051	6193	Looper Eccentric (cast iron) with two 1259c.....	4 00 50
1259c	6193	Looper Eccentric Set Screw.....	03
49116	6175	" Gate with 453c.....	1 00
49053	6181	" " Hinge Pin.....	10
453c	6181	" " " " Set Screw.....	02
49054	6181	" " Lock Spring.....	10
226D	6181	" " " " Screw.....	02
1147c	6193	" Set Screw.....	03
49080	6192	" Thread Guard.....	10
590D	6192	" " " Screw.....	02
49055	6194	Needle Bar (hollow).....	75
49117	6197	" " Bushing (lower).....	80 2 5
435c	6194	" " " " Set Screw..	04
49056	6194	" " " (upper).....	50 2 5
1133E	6194	" " " " Set Screw..	02 03

NO.	PLATE	NAME	EACH
49101	6194	Needle Bar Connecting Link.....	\$ 75
49057	6194	" " " " Hinge Stud	50
1517E	6194	" " " " " " "	---
		Nut.....	04
49058	6194	Needle Bar Connecting Stud with 391E.	50
391E	6194	" " " " Clamping Screw.....	02
1629c	6194	Needle Clamping Nut.....	08
49059	6195	Presser Bar.....	40
49060	6195	" " Bushing (lower).....	80 2 5
435c	6195	" " " " Set Screw.	04
49061	6195	" " " (upper).....	50 2 5
1133E	6195	" " " " Set Screw.	02
49062	6195	" " Lifter.....	75
212D	6195	" " " Cap Screw.....	04
49063	6195	" " " Friction Washer.....	02
49064	6195	" " " Hinge Stud.....	25
453c	6195	" " " " Set Screw	02
49065	6195	" " Lifting Bracket with 453c and 892F.....	1 25
892F	6195	Presser Bar Lifting Bracket Adjusting Screw.....	05
453c	6195	Presser Bar Lifting Bracket Set Screw..	02
49066	6195	" " " Link.....	25
212D	6195	" " " " Cap Screw...	04
724D	6195	" " " " Hinge Screw..	05
49067	6179	" " Spring (flat).....	50
38468	6195	" " Stud.....	03
50087F	6198	" Foot Hinge Screw.....	06
49118	---	" " Plate.....	2-25 11
49119	---	" " Shank.....	75 4
49120	6185	Presser Foot (hinged) complete for 49111, Nos. 49118, 49119 and 50087F.	8-00 11
50087F	6198	Presser Foot Hinge Screw.....	06
49126	---	" " Plate.....	1-00 75
49127	---	" " Shank.....	75 4
49128	6187	Presser Foot (hinged) complete for 49138, Nos. 49126, 49127 and 50087F	1-75 50
50087F	6198	Presser Foot Hinge Screw.....	06
49068	---	" " Plate.....	1-00 75
49069	---	" " Shank.....	75 4
49070	6186	Presser Foot (hinged) complete for 49025, Nos. 49068, 49069 and 50087F	1-75 50
190D	6198	Presser Foot Screw.....	03
574D	6198	Pressure Regulating Thumb Screw.....	15
1539D	6198	" " " " Lock Nut.....	05

NO.	PLATE	NAME	EACH
2102	6194	Tension (under thread) Disc.....	\$ 05
1560C	6194	" " " Regulating Thumb Nut.....	04
916F	6194	Tension (under thread) Screw Stud....	08
10148	6194	" " " Spring.....	03
17547	6194	" " " Thread Guide...	25
2102	6194	" (upper thread) Disc.....	05
1560C	6194	" " " Regulating Thumb Nut.....	04
916F	6194	Tension (upper thread) Screw Stud....	08
13710	6194	" " " Spring.....	03
17547	6194	" " " Thread Guide...	25
49071	6194	Thread (under) Eyelet.....	10
172F	6194	" " " Screw.....	04
49072	6196	" " Take-up.....	30
190D	6196	" " " Screw.....	03
49073	6196	" (upper) Controller.....	75
974F	6196	" " " Hinge Screw.	06
914F	6196	" " " Screw.....	04
39541	6196	" " " Washer	05
49075	6196	" " Take-up with 457C.....	80
457C	6196	" " " Set Screw.....	02
49121	6185	Throat Plate, for double thread, for 49111.....	1-50 100
49122	6185	Throat Plate with 665D and 49078, for single thread, for 49111.....	2-00 115
49139	6187	Throat Plate, for double thread, for 49138.....	1-50 110
49140	6187	Throat Plate with 665D and 49078, for single thread, for 49138.....	2-00 115
49136	6186	Throat Plate, for double thread, for 49025.....	1-00 115
49137	6186	Throat Plate with 665D and 49078, for single thread, for 49025.....	1-50 116
742F	6198	Throat Plate Screw.....	05
49078	6181	" " Thread Retainer.....	15
665D	6181	" " " " Screw....	02

IRON BASE

NO.	PLATE	NAME	EACH
49123	6199	Machine Base Oil Pipe.....	\$ 25
49124	6199	" " " " Valve.....	40
663E	6199	" " Screw.....	08
50144	6199	" " Thumb Screw with 49095	25
49095	6199	" " " " Washer.....	05
49096	6199	" Washer (leather).....	05
49094	6175	Machine Base with 49123, 49124 and three each 663E and 49096.....	2 50

ACCESSORIES

NO.	PLATE	NAME	EACH
25957	6201	Oiler with 25958.....	\$ 12
25958	6201	" Spout, 4 1/2 in. long.....	04
11831	6201	Screw Driver (large).....	20
26026	6201	" " (small).....	10
35095	6201	Tweezers, 6 in.....	40
19079	6201	Wrench for 1629.....	20
49079	6201	" " 1714.....	15
8908	6201	" " 1519, 1708 and 1709.....	08
8909	6201	" " 1513 and 1517.....	10
23766	6201	" " 1508 and 1636.....	10

HEMMER

NO.	PLATE	NAME	EACH
36436	6200	Hemmer on Shank, for burlap bags....	\$1 50
49125	6184	Feed Dog (double) for 92-1 Machine...	1-50
49111	6185	" " for heavy bags, for 92-2 Machine.....	3-00
49138	6187	Feed Dog, for medium and light bags, for 92-2 Machine.....	1-50
50087F	6198	Presser Foot Hinge Screw.....	06
49126	—	" " Plate.....	1-00
49127	—	" " Shank.....	75
49128	6184	Presser Foot (hinged) complete for 49125 and 49138, Nos. 49126, 49127 and 50087F.....	1-75
50087F	6198	Presser Foot Hinge Screw.....	06
49118	—	" " Plate.....	2-25

NO.	PLATE	NAME	EACH
49119	—	Presser Foot Shank.....	\$ 75 40
49120	6185	Presser Foot (hinged) complete for 49111, Nos. 49118, 49119 and 50087F.	2-00 110
49129	6184	Throat Plate, for double thread, for 49125.....	1 25 60
49130	6184	Throat Plate with 665D and 49078, for single thread, for 49125.....	1 75 75
49121	6185	Throat Plate, for double thread, for 49111.....	1 50 100
49122	6185	Throat Plate with 665D and 49078, for single thread, for 49111.....	2-00 115
49139	6187	Throat Plate, for double thread, for 49138.....	1 50 60
49140	6187	Throat Plate with 665D and 49078, for single thread, for 49138.....	2-00 75
49078	6181	Throat Plate Thread Retainer.....	15
665D	6181	" " " " Screw....	02

THREAD UNWINDER

FOR TWO LARGE SPOOLS OR TWO LARGE CONES OF THREAD

NO.	PLATE	NAME	EACH
27623	2837	Spool Pin.....	\$ 08
155C	6198	" " Set Screw.....	03
41530	2837	" Rest.....	30
41531	—	" " 41530 with 1149c and two each 155c and 27623.....	50
1149C	6198	Spool Rest Set Screw.....	04
27940	2837	" Stand with 453C.....	20
41514	2837	" Weight, 4 in. diam., with 41515..	15
41515	6199	" " Centre Pin.....	05
27739	2837	Thread Cone (wood).....	05
41631	2837	" Guard with 208E and two 41569	35
41569	6199	" " Eyelet.....	02
41637	2837	" " Rod (lower).....	10
41638	2837	" " " (upper).....	15
41639	2837	" " " Coupling with two 456C.....	20
456C	6198	Thread Guard Rod Coupling Set Screw.	02
41640	—	Thread Guard Rod complete, 30 in. long, Nos. 41637 to 41639.....	45
453C	6181	Thread Guard Rod Set Screw.....	02
208E	6198	" " Screw.....	02
41533	2837	Thread Unwinder complete, Nos. 27940, 41531, 41631, 41640, two each 27739, 41514 and three wood screws 1 in. No. 12.....	1 80

UNDER DRIVER

LEVER PRESSURE, THREE SPEED, RIGHT HAND
(OIL CONTROLLING PULLEY)

NO.	PLATE	NAME	EACH
27508	362	Belt Guard.....	\$ 08
649E	6198	" " Screw.....	05
27509	362	Cone Pulley (grooved) three speed, 2½ in., 3¼ in. and 5¼ in. diam., with 27473.....	60
27473	1101	Cone Pulley Centre Bearing.....	08
27474	363	Dress Guard (right hand).....	08
138E	1101	" " Screw.....	05
27630	362	Driving Pulley (grooved) 6 in. diam., with 433C, 27598 and two 7958.....	60
27598	—	Driving Pulley Friction Ring (leather)..	05
7958	2642	" " " " Stop Pin..	01
27631	1101	" " Hollow Stud with 27600	15
27600	1101	" " " " Position Stud.....	02
356C	6198	Driving Pulley Hollow Stud Set Screw..	06
27632	—	" " " " Wick.....	01
27633	—	" " " " " Wire with 27632.....	05
433C	1101	Driving Pulley Screw Centre Bearing	08
7958	2642	" " " " " "	01
27634	362	Dowel Pin.....	01
41338	362	Frame.....	60
27483	1101	Lever.....	25
27497	1101	" Brake Spring.....	02
12178	1101	" " Strip (leather).....	02
427E	1101	" Centre Plug (wood).....	01
1508E	1101	" " " " Adjusting Screw.....	08
27485	1101	" " " " " Nut	06
27635	362	" Hinge Pin.....	01
145E	6198	Oil Cup.....	25
27070	363	" " Screw.....	04
597C	2642	Shaft Driving Pulley (sectional, grooved) 10 in. diam., 1⅜ in. bore, with two 597C.....	45
27636	363	Shaft Driving Pulley Clamping Screw..	08
9082	1101	Treadle.....	30
27637	362	" Bearing Cotter Pin.....	01
27638	1101	" Pitman Rod (lower).....	05
27638	1101	" " " " Spring....	03

From the Library of Diamond Needle Company

NO.	PLATE	NAME	EACH
27639	362	Treadle Pitman Rod (upper).....	\$ 05
9079	362	“ “ “ Clamp with 354c... 12	
354C	1101	“ “ “ “ Screw.....	06
27640	362	Treadle Pitman complete, Nos. 2762, 9079 and 27637 to 27639.....	35
2878	363	Treadle Stand.....	15
2762	2642	“ Stop Collar with 362F.....	10
362F	2642	“ “ “ Set Screw.....	05
27642	—	Treadle complete, Nos. 2878, 9082, 27636 and four wood screws 1 in. No. 16.....	45
27643	—	Treadle and Pitman complete, Nos. 27640 and 27642.....	80
27644	—	Transmitter complete for 27645, Nos. 138E, 356C, 427E, 649E, 1508E, 12178, 27474, 27483, 27485, 27497, 27508, 27509, 27630, 27631, 27633 to 27635, 41338, two 145E and four wood screws 1½ in. No. 16.....	3 00
27645	—	Under Driver, lever pressure, three speed, right hand (oil-controlling pulley) complete, Nos. 27070, 27643 and 27644.....	4 00

UNDER DRIVER

(BALL BEARING)

LEVER PRESSURE, TWO SPEED, RIGHT HAND

NO.	PLATE	NAME	EACH
27750	2640	Cone Pulley (grooved) two speed, 3¼ in. and 5¼ in. diam., with 878D and 12459.....	\$ 60
25303	2641	Cone Pulley Ball, size ¼ in.....	1 00
27753	2641	“ “ “ Bearing Adjusting Ring.....	15
1143C	2641	Cone Pulley Ball Bearing Adjusting Ring Set Screw.....	03
27795	2641	Cone Pulley Ball Bearing Adjusting Ring Set Screw Washer.....	per 100 25
878D	2641	Cone Pulley Oil Hole Stop Screw.....	06
12459	2641	“ “ “ “ “ Washer (leather).....	per 100 50
27755	2640	Dress Guard.....	10
348C	2642	“ “ Screw.....	06
2718	2642	“ “ Washer.....	01

NO.	PLATE	NAME	EACH
27756	2640	Driving Pulley (grooved) 6 in. diam., with 315c, 7958 and 27598.....	\$ 60
27598	—	Driving Pulley Friction Ring (leather).....	05
7958	2642	“ “ “ “ Stop Pin.....	01
315C	2642	“ “ Set Screw.....	04
27757	2641	“ “ Shaft.....	60
25303	2641	“ “ “ Ball, size ¼ in. per 100.....	1 00
27751	2641	Driving Pulley Shaft Ball Bearing Collar.....	25
27752	2641	“ “ “ “ “ “ Pin.....	04
27758	2641	Driving Pulley Shaft Ball Safety Washer.....	01
27759	2641	“ “ “ Screw Bearing Ball Case (left).....	20
27760	—	Driving Pulley Shaft Screw Bearing Ball Case (left) complete, Nos. 27758, 27759, 27761 to 27763 and twelve 25303.....	50
27761	2641	Driving Pulley Shaft Screw Bearing Ball Case (left) Friction Stud.....	10
25303	2641	Driving Pulley Shaft Screw Bearing Ball Case (left) Friction Stud Ball, size ¼ in.....	per 100 1 00
27762	2641	Driving Pulley Shaft Screw Bearing Ball Case (left) Friction Stud Ball Plate.....	05
27763	2641	Driving Pulley Shaft Screw Bearing Ball Case (left) Friction Stud Ball Plate Washer.....	01
27754	2641	Driving Pulley Shaft Screw Bearing Ball Case (left) Friction Stud Extension Pin.....	08
1122C	2641	Driving Pulley Shaft Screw Bearing Ball Case (left) Set Screw.....	03
27764	2641	Driving Pulley Shaft Screw Bearing Ball Case (right).....	20
27765	—	Driving Pulley Shaft Screw Bearing Ball Case (right) complete, Nos. 27758, 27764 and eight 25303.....	30
1122C	2641	Driving Pulley Shaft Screw Bearing Ball Case (right) Set Screw.....	03
27766	2640	Frame with two 1122c.....	75
27767	2640	Lever with 27768 and two 27878.....	35
1093C	2642	“ Adjusting Screw.....	10
1513E	2642	“ “ “ Nut.....	05
27768	2642	“ Brake (leather, two pieces).....	03
27878	2642	“ “ Rivet.....	01
1092E	2642	“ Hinge Screw.....	20
1507E	2642	“ “ “ Nut.....	05

NO.	PLATE	NAME	EACH
27769	2642	Lever Spring.....	\$ 10
27070	363	Shaft Driving Pulley (sectional, grooved) 10 in. diam., 1 $\frac{3}{16}$ in. bore, with two 597C.....	45
597C	2642	Shaft Driving Pulley Clamping Screw..	08
27636	363	Treadle.....	30
9082	2642	" Bearing Cotter Pin.....	01
27637	2640	" Pitman Rod (lower).....	05
27638	2642	" " " " Spring.....	03
27639	2640	" " " (upper).....	05
9079	2640	" " " Clamp with 354C...	12
354C	2642	" " " " Screw.....	06
27640	2640	Treadle Pitman complete, Nos. 2762, 9079 and 27637 to 27639.....	35
2878	363	Treadle Stand.....	15
2762	2642	" Stop Collar with 362F.....	10
362F	2642	" " " " Set Screw.....	05
27642	—	Treadle complete, Nos. 2878, 9082, 27636 and four wood screws 1 in. No. 16.....	45
27643	—	Treadle and Pitman complete, Nos. 27640 and 27642.....	80
27770	—	Transmitter complete, Nos. 348C, 1092E, 1093C, 1507E, 1513E, 2718, 27750 to 27752, 27754 to 27757, 27760, 27765 to 27767, 27769, two each 1143C, 27753, 27795, three wood screws 2 in. No. 16 and twenty-two 25303.....	3 00
27771	—	Under Driver (ball bearing) lever pressure, two speed, right hand, com- plete, Nos. 27070, 27643 and 27770..	4 00

OBSOLETE PARTS

NO.	PLATE	NAME	EACH
49002	6202	Arm Rock Shaft.....	\$ 75
49007	6203	" " " Crank (back) with 1259C and 50083C.....	1 50
1259C	6177	Arm Rock Shaft Crank (back) Set Screw	03
49009	6202	" Rotary Shaft.....	2 50
49015	6175	Cloth Plate.....	2 00 1 75
49018	—	Cloth Plate complete, Nos. 49015, 49017H, 49052 to 49054 and two 226D	4 65 3 30
49019	6202	Crank Connecting Rod with 4784, 46222, 46223 and two each 896E and 1057E.	2 00 1 50
49098	6202	Crank Connecting Rod with 49099, 49100 and two each 145E and 896E..	2 00 1 50
50069	6203	Crank Connecting Rod Ball Screw Stud	20
1619E	6203	" " " " " " "	05
49102	6203	Nut.....	05
49102	6203	Crank Connecting Rod Ball Screw Stud Washer.....	05
*46222	—	Crank Connecting Rod Cap (lower) for 49019.....	25
*49099	—	Crank Connecting Rod Cap (lower) for 49098.....	—
896E	6180	Crank Connecting Rod Cap (lower) Screw for 49019.....	04
145E	6198	Crank Connecting Rod Cap (lower) Screw for 49098.....	04
*46223	—	Crank Connecting Rod Cap (upper) for 49019.....	35
*49100	—	Crank Connecting Rod Cap (upper) for 49098.....	—
1057E	6180	Crank Connecting Rod Cap (upper) Screw for 49019.....	04
896E	6180	Crank Connecting Rod Cap (upper) Screw for 49098.....	04
4784	6180	Crank Connecting Rod Oil Pad (felt)...	01
46225	6203	" " " Washer (fibre)...	02
36221	6200	Guide.....	15
*46238	—	Looper Carrier Pitman Cap (left).....	—
*46238	—	" " " " (right).....	—
*46239	—	" " " " End Bearing (left).....	—
*46240	—	Looper Carrier Pitman End Bearing (right).....	—

From the library of: Diamond Needle Corp

OBSOLETE PARTS

NO.	PLATE	NAME	EACH
46241	—	Looper Carrier Pitman Head (left) Nos. 46237 to 46239 and two 171E.....	\$1 50
46242	—	Looper Carrier Pitman Head (right) Nos. 46238, 46240, 50070c and two 171E.....	1 50
49052	6175	Looper Gate with 448c.....	1 00
448c	6181	" " Hinge Pin Set Screw.....	03
38458	6203	Needle Bar Connecting Link.....	50
2102	6194	Thread (upper) Retainer Disc.....	05
49074	6203	" " " Guide Pin.....	01
1560c	6194	" " " Regulating Thumb Nut.....	04
417F	6203	Thread (upper) Retainer Screw Stud...	08
10148	6194	" " " Spring.....	03
49076	6204	Throat Plate, for double thread, for 49025 and 49103, for 49015.....	1 00
49077	6204	Throat Plate with 665D and 49078, for single thread, for 49025 and 49103, for 49015.....	1 50
49083	6204	Throat Plate, for double thread, for 49081 for 49015.....	1 00
49090	6204	Throat Plate with 665D and 49078, for single thread, for 49081 for 49015 ...	1 50

NUMERICAL LIST OF PARTS

NUMERICAL LIST OF PARTS

NO.	PLATE	NAME	EACH
348C	2642	Under Driver Dress Guard Screw for 27770.....	\$ 06
354C	1101	Under Driver Treadle Pitman Rod Clamp Screw for 9079.....	06
356C	6198	Under Driver Driving Pulley Hollow Stud Set Screw for 27644.....	06
362F	2642	Under Driver Treadle Stop Collar Set Screw for 2762.....	05
391E	6194	Needle Bar Connecting Stud Clamping Screw for 49058.....	02
417F	6203	Thread (upper) Retainer Screw Stud, obsolete.....	08
427E	1101	Under Driver Lever Centre Plug Adjusting Screw for 27644.....	08
430C	6177	Arm Rock Shaft Flanged Bushing (front) Set Screw.....	04
430C	6181	Arm Rotary Shaft Bushing (front) Set Screw.....	04
430C	6177	Balance Wheel Set Screw for 23873.....	04
433C	1101	Under Driver Driving Pulley Screw Centre Bearing for 27630.....	08
435C	6194	Needle Bar Bushing (lower) Set Screw.....	04
435C	6195	Presser Bar Bushing (lower) Set Screw.....	04
443C	6177	Arm Rock Shaft Collar Set Screw for 49006.....	03
446C	6177	Arm Rock Shaft Bushing (back) Set Screw.....	03
446C	6177	Arm Rock Shaft Bushing (intermediate) Set Screw.....	03
448C	6181	Arm Rotary Shaft Flanged Bushing (intermediate) Set Screw.....	03
448C	6181	Looper Bell Crank Hinge Stud Set Screw	03
448C	6181	" Gate Hinge Pin Set Screw for 49052, obsolete.....	03
453C	6193	Looper Carrier Rock Shaft Collar Set Screw for 11411.....	02
453C	6181	Looper Gate Hinge Pin Set Screw for 49116.....	02
453C	6195	Presser Bar Lifter Hinge Stud Set Screw	02
453C	6195	" " Lifting Bracket Set Screw for 49065.....	02
453C	6181	Thread Unwinder Thread Guard Rod Set Screw for 27940.....	02
456C	6198	Thread Unwinder Thread Guard Rod Coupling Set Screw for 41639.....	02
457C	6180	Feed Bar Hinge Pin Set Screw for 49021 and 49110.....	02

NUMERICAL LIST OF PARTS

NO.	PLATE	NAME	EACH
457C	6180	Feed Lifting Eccentric Connection Hinge Pin Set Screw for 49028.....	\$ 02
457C	6196	Thread (upper) Take-up Set Screw for 49075.....	02
574D	6198	Pressure Regulating Thumb Screw.....	15
590D	6192	Looper Thread Guard Screw for 49036.....	02
597C	2642	Under Driver Shaft Driving Pulley Clamping Screw for 27070.....	08
622C	6198	Feed Rock Shaft Hinge Pin Screw Bearing.....	12
649E	6198	Under Driver Belt Guard Screw for 27644.....	05
663E	6199	Machine Base Screw for 49094.....	08
665D	6181	Throat Plate Thread Retainer Screw for 49077, 49090, 49122, 49130, 49132, 49134 and 49137.....	02
671D	6200	Guide Thumb Screw.....	10
691F	6198	Throat Plate Screw for 92-1 Machine.....	04
724D	6195	Presser Bar Lifting Link Hinge Screw.....	05
725H	6181	Cloth Plate Slide Spring Screw for 49017H.....	02
742F	6198	Throat Plate Screw for 92-2 Machine.....	05
878D	2641	Under Driver Cone Pulley Oil Hole Stop Screw for 27750.....	06
892F	6195	Presser Bar Lifting Bracket Adjusting Screw for 49065.....	05
896E	6180	Crank Connecting Rod Adjusting Screw for 49108.....	04
896E	6180	Crank Connecting Rod Cap (lower) Screw for 49019, obsolete.....	04
896E	6180	Crank Connecting Rod Cap (upper) Screw for 49098, obsolete.....	04
896E	6180	Feed Connecting Rod Cap Screw for 49023.....	04
896E	6180	Feed Rock Shaft Crank Clamping Screw for 49035 and 49115.....	04
914F	6196	Thread (upper) Controller Screw.....	04
916F	6194	Tension (under thread) Screw Stud.....	08
916F	6194	" (upper) " " ".....	08
974F	6196	Thread (upper) Controller Hinge Screw	06
1036C	6177	Arm Rock Shaft Crank (back) Set Screw for 49104.....	03
1057E	6180	Crank Connecting Rod Cap (upper) Screw for 49019, obsolete.....	04
1057E	6180	Feed Lifting Eccentric Connection Cap Screw for 49028.....	04
1092E	2642	Under Driver Lever Hinge Screw for 27770.....	20

NUMERICAL LIST OF PARTS

NO.	PLATE	NAME	EACH
1093C	2642	Under Driver Lever Adjusting Screw for 27770.....	\$ 10
1122C	2641	Under Driver Driving Pulley Shaft Screw Bearing Ball Case (left) Set Screw for 27766.....	03
1122C	2641	Under Driver Driving Pulley Shaft Screw Bearing Ball Case (right) Set Screw for 27766.....	03
1133E	6194	Needle Bar Bushing (upper) Set Screw.	02
1133E	6195	Presser Bar Bushing (upper) Set Screw.	02
1143C	2641	Under Driver Cone Pulley Ball Bearing Adjusting Ring Set Screw for 27770..	03
1147C	6192	Looper Carrier Hinge Pin Set Screw for 49044.....	03
1147C	6192	Looper Carrier Pitman Ball Stud (left) Set Screw.....	03
1147C	6193	Looper Set Screw for 49050.....	03
1149C	6198	Thread Unwinder Spool Rest Set Screw for 41531.....	04
1253C	6193	Looper Carrier Rock Shaft Crank (front) Set Screw for 49050.....	03
1259C	6177	Arm Rock Shaft Crank (back) Set Screw for 49007, obsolete.....	03
1259C	6177	Arm Rotary Shaft Collar Set Screw for 49010.....	03
1259C	6180	Feed Eccentric Set Screw for 49026 and 49112.....	03
1259C	6180	Feed Lifting Eccentric Set Screw for 49027 and 49113.....	03
1259C	6193	Looper Eccentric Set Screw for 49051..	03
1507E	2642	Under Driver Lever Hinge Screw Nut for 27770.....	05
1508E	6198	Feed Rock Shaft Hinge Pin Nut.....	06
1508E	6198	" " " " " Screw Bearing Nut.....	06
1508E	1101	Under Driver Lever Centre Plug Adjusting Screw Nut for 27644.....	06
1513E	6198	Crank Connecting Rod Hinge Screw Nut	05
1513E	2642	Under Driver Lever Adjusting Screw Nut for 27770.....	05
1517E	6194	Needle Bar Connecting Link Hinge Stud Nut.....	04
1519E	6192	Looper Carrier Pitman Ball Screw Stud (right) Nut.....	03
1539D	6198	Pressure Regulating Thumb Screw Lock Nut.....	05
1560C	6194	Tension (under thread) Regulating Thumb Nut.....	04

NUMERICAL LIST OF PARTS

NO.	PLATE	NAME	EACH
1560C	6194	Tension (upper thread) Regulating Thumb Nut.....	\$ 04
1560C	6194	Thread (upper) Retainer Regulating Thumb Nut, obsolete.....	04
1619E	6203	Crank Connecting Rod Ball Screw Stud Nut, obsolete.....	05
1629C	6194	Needle Clamping Nut.....	08
1636E	6198	Looper Bell Crank Pitman Ball Screw Stud (lower) Nut.....	03
1636E	6198	Looper Bell Crank Pitman Ball Screw Stud (upper) Nut.....	03
1708E	6192	Looper Carrier Pitman Rod Nut (left) for 49045.....	03
1709E	6192	Looper Carrier Pitman Rod Nut (right) for 49045.....	03
1714C	6181	Feed Regulating Screw Stud Nut.....	04
2102	6194	Tension (under thread) Disc.....	05
2102	6194	" (upper ") ".....	05
2102	6194	Thread (upper) Retainer Disc, obsolete	05
2653	6180	Feed Connecting Rod Oil Pad Pin for 49023.....	01
2653	6180	Feed Lifting Eccentric Connection Oil Pad Pin for 49028.....	01
2718	2642	Under Driver Dress Guard Screw Washer for 27770.....	01
2762	2642	Under Driver Treadle Stop Collar with 362F, for 27640.....	10
2878	363	Under Driver Treadle Stand for 27642..	15
4288H	6179	Arm Side Cover (lower).....	10
4288H	6179	" " " (upper).....	10
4784	6180	Crank Connecting Rod Oil Pad (felt) for 49019, obsolete.....	01
4784	6180	Feed Connecting Rod Oil Pad (felt) for 49023.....	01
4784	6180	Feed Lifting Eccentric Connection Oil Pad (felt) for 49028.....	01
4784	6180	Looper Bell Crank Oil Pad (felt) for 49038.....	01
4784	6192	Looper Carrier Oil Pad (felt) for 49044.	01
7958	2642	Under Driver Driving Pulley Friction Ring Stop Pin for 27630 and 27756..	01
7958	2642	Under Driver Driving Pulley Screw Centre Bearing Dowel Pin for 27630.	01
8908	6201	Wrench for 1519, 1708 and 1709 (Accessories).....	08
8909	6201	Wrench for 1513 and 1517 (Accessories)	10
9079	362	Under Driver Treadle Pitman Rod Clamp with 354C, for 27640.....	12

From the library of: Diamond Needle Corp

NUMERICAL LIST OF PARTS

NO.	PLATE	NAME	EACH
27644	—	Under Driver Transmitter complete for 27645, Nos. 138E, 356C, 427E, 649E, 1508E, 12178, 27474, 27483, 27485, 27497, 27508, 27509, 27630, 27631, 27633 to 27635, 41338, two 145E and four wood screws 1½ in. No. 16.....	\$3 00
27645	—	Under Driver, lever pressure, three speed right hand (oil-controlling pulley) complete, Nos. 27070, 27643 and 27644.....	4 00
27739	2837	Thread Unwinder Thread Cone (wood) for 41533.....	05
Nos. 27750 TO 27757 FOR 27770.			
27750	2640	Under Driver Cone Pulley (grooved) two speed, 3¾ in. and 5¼ in. diam., with 878D and 12459.....	60
27751	2641	Under Driver Driving Pulley Shaft Ball Bearing Collar.....	25
27752	2641	Under Driver Driving Pulley Shaft Ball Bearing Collar Pin.....	04
27753	2641	Under Driver Cone Pulley Ball Bearing Adjusting Ring.....	15
27754	2641	Under Driver Driving Pulley Shaft Screw Bearing Ball Case (left) Friction Stud Extension Pin.....	02
27755	2640	Under Driver Dress Guard.....	10
27756	2640	" " Driving Pulley (grooved) 6 in. diam., with 315C, 7958 and 27598.....	60
27757	2641	Under Driver Driving Pulley Shaft.....	60
27758	2641	" " " " " Ball Safety Washer for 27760 and 27765.....	01
27759	2641	Under Driver Driving Pulley Shaft Screw Bearing Ball Case (left) for 27760.....	20
27760	—	Under Driver Driving Pulley Shaft Screw Bearing Ball Case (left) complete for 27770, Nos. 27758, 27759, 27761 to 27763 and twelve 25303.....	50
Nos. 27761 TO 27763 FOR 27760.			
27761	2641	Under Driver Driving Pulley Shaft Screw Bearing Ball Case (left) Friction Stud.....	10
27762	2641	Under Driver Driving Pulley Shaft Screw Bearing Ball Case (left) Friction Stud Ball Plate.....	05

NUMERICAL LIST OF PARTS

NO.	PLATE	NAME	EACH
27763	2641	Under Driver Driving Pulley Shaft Screw Bearing Ball Case (left) Friction Stud Ball Plate Washer.....	\$ 01
27764	2641	Under Driver Driving Pulley Shaft Screw Bearing Ball Case (right) for 27765.....	20
Nos. 27765 TO 27767 FOR 27770.			
27765	—	Under Driver Driving Pulley Shaft Screw Bearing Ball Case (right) complete, Nos. 27758, 27764 and eight 25303.....	30
27766	2640	Under Driver Frame with two 1122C....	75
27767	2640	" " Lever with 27768 and two 27878.....	35
27768	2642	Under Driver Lever Brake (leather) two pieces, for 27767.....	03
27769	2642	Under Driver Lever Spring for 27770...	10
27770	—	Under Driver Transmitter complete for 27771, Nos. 348C, 1092E, 1093C, 1507E, 1513E, 2718, 27750 to 27752, 27754 to 27757, 27760, 27765 to 27767, 27769, two each 1143C, 27753, 27795, three wood screws 2 in. No. 16 and twenty-two 25303.....	3 00
27771	—	Under Driver (ball bearing) lever pressure, two speed, right hand, complete, Nos. 27070, 27643 and 27770...	4 00
27795	2641	Under Driver Cone Pulley Ball Bearing Adjusting Ring Set Screw Washer for 27770..... per 100	25
27878	2642	Under Driver Lever Brake Rivet for 27767.....	01
27940	2837	Thread Unwinder Spool Stand with 453C, for 41533.....	20
29599	6178	Arm Oil Tube Packing (felt) for 11119, 12454 and 18130..... per 100	25
35095	6201	Tweezers, 6 in. (Accessories).....	40
36221	6200	Guide, obsolete.....	15
36421	6200	Guide.....	15
36436	6200	Hemmer on Shank, for burlap bags....	1 50
38419	6181	Cloth Plate Slide Spring for 49017H....	05
38440	6192	Looper Carrier Hinge Pin.....	20
38458	6203	Needle Bar Connecting Link, obsolete..	50
38468	6195	Presser Bar Spring Stud.....	03
39541	6196	Thread (upper) Controller Screw Washer	05
41338	362	Driver Lever for 27644.....	25

From the library of: Diamond Needle Corp

NO.	PLATE	NAME	EACH
41514	2837	Thread Unwinder Spool Weight, 4 in. diam., with 41515, for 41533.....	\$ 15
41515	6199	Thread Unwinder Spool Weight Centre Pin for 41514.....	05
41530	2837	Thread Unwinder Spool Rest for 41531.	30
41531	—	" " " " 41530 with 1149c and two each 155c and 27623, for 41533.....	50
41533	2837	Thread Unwinder complete, for two large spools or two large cones of thread, Nos. 27940, 41531, 41631, 41640, two each 27739, 41514 and three wood screws 1 in. No. 12.....	1 80
41569	6199	Thread Unwinder Thread Guard Eyelet for 41631.....	02
41631	2837	Thread Unwinder Thread Guard with 208E and two 41569, for 41533..... Nos. 41637 to 41639 for 41640.	35
41637	2837	Thread Unwinder Thread Guard Rod (lower).....	10
41638	2837	Thread Unwinder Thread Guard Rod (upper).....	15
41639	2837	Thread Unwinder Thread Guard Rod Coupling with two 456c.....	20
41640	—	Thread Unwinder Thread Guard Rod complete, 30 in. long, for 41533, Nos. 41637 to 41639.....	45
*46222	—	Crank Connecting Rod Cap (lower) for 49019, obsolete.....	25
*46223	—	Crank Connecting Rod Cap (upper) for 49019, obsolete.....	35
46225	6203	Crank Connecting Rod Washer (fibre) obsolete.....	02
46237	6192	Looper Carrier Pitman Ball Stud (left) for 46241 and 49088.....	25
*46238	—	Looper Carrier Pitman Cap (left) for 46241, obsolete.....	—
*46238	—	Looper Carrier Pitman Cap (right) for 46242, obsolete.....	—
*46239	—	Looper Carrier Pitman End Bearing (left) for 46241, obsolete.....	—
*46240	—	Looper Carrier Pitman End Bearing (right) for 46242, obsolete.....	—
46241	—	Looper Carrier Pitman Head (left) Nos. 46237 to 46239 and two 171E, obsolete	1 50
46242	—	Looper Carrier Pitman Head (right) Nos. 46238, 46240, 50070c and two 171E, obsolete.....	1 50

NO.	PLATE	NAME	EACH
*49001	—	Arm, upper and lower (solid).....	\$30 00
49002	6202	" Rock Shaft, obsolete.....	75
49003	6177	" " " Bushing (back).....	95 15
49004	6177	" " " " (intermediate).....	35
49005	6177	" " " Flanged Bushing (front).....	50
49006	6177	Arm Rock Shaft Collar with two 443c..	30
49007	6203	" " " Crank (back) with 1259c and 50083c, obsolete.....	1 50
49008	6177	Arm Rock Shaft Crank (front) with two 50084c.....	1 00
49009	6202	Arm Rotary Shaft, obsolete.....	2 50
49010	6177	" " " Collar with two 1259c.....	30
49011	6181	Arm Rotary Shaft Bushing (front).....	35
49012	6179	" " " Flanged Bushing (back).....	50
49013	6178	Arm Rotary Shaft Flanged Bushing (back) Oil Pad, short (braided cotton)	01
49014	6181	Arm Rotary Shaft Flanged Bushing (intermediate).....	50
49015	6175	Cloth Plate for 49018, obsolete.....	00 15
49016H	—	" " Slide for 49017H.....	30
49017H	6179	Cloth Plate Slide complete for 49018 and 49107, Nos. 38419, 49016H and two 725H.....	40
49018	—	Cloth Plate complete, Nos. 49015, 49017H, 49052 to 49054 and two 226D, obsolete.....	65 30
49019	6202	Crank Connecting Rod with 4784, 46222, 46223 and two each 896E and 1057E, obsolete.....	00 15
49020H	6179	Face Plate.....	75
49021	6180	Feed Bar with 220D and 457C, for 92-1 Machine.....	2 50
49022	6180	Feed Bar Hinge Pin.....	10
49023	6180	" Connecting Rod with 2653, 4784, 49024 and two 896E.....	1 00
*49024	—	Feed Connecting Rod Cap for 49023.....	—
49025	6182	" Dog, for large bags.....	1 00
49026	6180	" Eccentric (cast iron) with two 1259c, for 92-1 Machine.....	1 00
49027	6180	Feed Lifting Eccentric (cast iron) with two 1259c, for 92-1 Machine.....	1 00
49028	6180	Feed Lifting Eccentric Connection with 457c, 2653, 4784, 49029 and two 1057E	1 50
*49029	—	Feed Lifting Eccentric Connection Cap for 49028.....	—

NUMERICAL LIST OF PARTS

NO.	PLATE	NAME	EACH
49030	6180	Feed Lifting Eccentric Connection Hinge Pin.....	\$ 10
49031	6181	Feed Regulating Screw Stud Sleeve....	50
49032	6181	" " " " Washer....	05
49033	6179	" Rock Shaft for 49034 and 49114..	1 00
49034	—	Feed Rock Shaft complete for 92-1 Machine, Nos. 49033 and 49035.....	2-50 175
49035	6179	Feed Rock Shaft Crank with two 896E, for 49034.....	1-50 75
49036	6192	Looper (double thread) with 590D and 49080.....	2 25 70
49037	6192	Looper (single thread).....	2 25 70
49038	6176	" Bell Crank with 4784.....	2-50 70
49039	6176	" " " Hinge Stud.....	60 60
49040	6176	" " " Pitman with 175E, 49041, 49042 and three 171E.....	2-00 175
*49041	—	Looper Bell Crank Pitman Cap (lower) for 49040.....	—
*49042	—	Looper Bell Crank Pitman Cap (upper) for 49040.....	—
49043	6192	Looper Bell Crank Pitman Washer (fibre).....	02
49043	6192	Looper Carrier Pitman Washer (fibre)...	02
49044	6192	" " with 4784 and two each 175D and 1147C.....	2-50 100
49045	6192	Looper Carrier Pitman complete, Nos. 1708E, 1709E, 49046, 49088 and 49089.	3 25
49046	6192	Looper Carrier Pitman Rod for 49045..	10
49047	6193	" " Rock Shaft.....	50
49048	6193	" " " " Crank (back) forked, with 50083C.....	2-00 125
49049	6193	Looper Carrier Rock Shaft Crank (back) Slide Block.....	1 50
49050	6193	Looper Carrier Rock Shaft Crank (front) with 1147C and two 1253C.....	75
49051	6193	Looper Eccentric (cast iron) with two 1259C.....	1-00 50
49052	6175	Looper Gate with 448c, for 49018, obsolete.....	1 00
49053	6181	Looper Gate Hinge Pin for 49018 and 49107.....	10
49054	6181	Looper Gate Lock Spring for 49018 and 49107.....	10
49055	6194	Needle Bar (hollow).....	75
49056	6194	" " Bushing (upper).....	50 25
49056	6194	" " " (lower) for 92-1 Machine.....	50 25

NUMERICAL LIST OF PARTS

NO.	PLATE	NAME	EACH
49057	6194	Needle Bar Connecting Link Hinge Stud.....	\$ 50
49058	6194	Needle Bar Connecting Stud with 391E.	50
49059	6195	Presser Bar.....	40
49060	6195	" " Bushing (lower).....	80
49061	6195	" " " (upper).....	50
49062	6195	" " Lifter.....	75
49063	6195	" " " Friction Washer.....	02
49064	6195	" " " Hinge Stud.....	25
49065	6195	" " Lifting Bracket with 453C and 892F.....	1 25
49066	6195	Presser Bar Lifting Link.....	25
49067	6179	" " Spring (flat).....	50
49068	—	" Foot Plate for 49070.....	1-00
49069	—	" " Shank for 49070.....	75
49070	6182	Presser Foot (hinged) complete for 49025 and 49103, Nos. 49068, 49069 and 50087F.....	1-75
49071	6194	Thread (under) Eyelet.....	10
49072	6196	" " Take-up.....	30
49073	6196	" (upper) Controller.....	75
49074	6203	" " Retainer Guide Pin, obsolete.....	01
49075	6196	Thread (upper) Take-up with 457C.....	80
49076	6204	Throat Plate, for double thread, for 49025 and 49103, for 49015, obsolete..	1 00
49077	6204	Throat Plate with 665D and 49078, for single thread, for 49025 and 49103, for 49015, obsolete.....	1 50
49078	6181	Throat Plate Thread Retainer for 49077, 49090, 49122, 49130, 49132, 49134, 49137 and 49140.....	15
49079	6201	Wrench for 1714 (Accessories).....	15
49080	6192	Looper Thread Guard for 49036.....	10
49081	6183	Feed Dog, for small bags, for 92-1 Machine.....	75
49082	6183	Presser Foot for 49081.....	1 00
49083	6204	Throat Plate, for double thread, for 49081 for 49015, obsolete.....	1 00
49084	6181	Arm Rock Shaft Oil Cover.....	10
*49085	—	Looper Carrier Pitman Cap (left) for 49088.....	—
*49085	—	Looper Carrier Pitman Cap (right) for 49089.....	—
*49086	—	Looper Carrier Pitman End Bearing (left) for 49088.....	—
*49087	—	Looper Carrier Pitman End Bearing (right) for 49089.....	—

From the library of David Seedling

NUMERICAL LIST OF PARTS

NO.	PLATE	NAME	EACH
49088	—	Looper Carrier Pitman Head (left) Nos. 46237, 49085, 49086 and two 171E. for 49045.	\$1 50
49089	—	Looper Carrier Pitman Head (right) Nos. 49085, 49087, 50070c and two 171E. for 49045.	1 50
49090	6204	Throat Plate with 665D and 49078, for single thread, for 49081, for 49015, obsolete.	1 50
49091	6178	Arm Oil Tube with 49092, for oiling 49108.	20
49092	6178	Arm Oil Tube Packing (felt) for 49091.	01
49093	6178	" Rotary Shaft Flanged Bushing (back) Oil Pad, long (braided cotton)	02
49094	6175	Machine Base with 49123, 49124 and three each 663E and 49096.	2 50
49095	6199	Machine Base Thumb Screw Washer for 50144.	05
49096	6199	Machine Washer (leather) for 49094.	05
49097	6176	Arm Rotary Shaft for 92-1 Machine.	2 50
49098	6202	Crank Connecting Rod with 49099, 49100 and two each 145E and 896E, obsolete.	2-00 150
*49099	—	Crank Connecting Rod Cap for 49108.	—
*49099	—	" " " " (lower) for 49098, obsolete.	—
*49100	—	Crank Connecting Rod Cap (upper) for 49098, obsolete.	—
49101	6194	Needle Bar Connecting Link.	75
49102	6203	Crank Connecting Rod Ball Screw Stud Washer, obsolete.	05
49103	6182	Feed Dog (spiked teeth) for clay-filled bags, for 92-1 Machine.	1-00 60
49104	6177	Arm Rock Shaft Crank (back) with 1036c and 50083c.	1 50
49105	6176	Arm Rotary Shaft for 92-2 Machine.	2 50
49106	6175	Cloth Plate for 49107.	3-00 175
49107	—	Cloth Plate complete, Nos. 49017H, 49053, 49054, 49106, 49116 and two 226D.	4-05 330
49108	6176	Crank Connecting Rod with 896E, 49099, 49109 and two 145E.	2-00 150
49109	6181	Crank Connecting Rod Adjusting Washer for 49108.	01
49110	6197	Feed Bar with 457c, for 92-2 Machine.	2-50 75
49111	6185	" Dog, for heavy bags, for 92-2 Machine and 36436.	2-00 100

NUMERICAL LIST OF PARTS

NO.	PLATE	NAME	EACH
Nos. 49112 TO 49115 FOR 92-2 MACHINE.			
49112	6197	Feed Eccentric (cast iron) with two 1259c.	\$1 00
49113	6197	Feed Lifting Eccentric (cast iron) with two 1259c.	1-00
49114	—	Feed Rock Shaft complete, Nos. 49033 and 49115.	2 50
49115	6179	Feed Rock Shaft Crank with two 896E, for 49114.	1-50
49116	6175	Looper Gate with 453c, for 49107.	1 00
Nos. 49117 TO 49122 FOR 92-2 MACHINE.			
49117	6197	Needle Bar Bushing (lower).	80
49118	—	Presser Foot Plate for 49120.	25
49119	—	" " Shank for 49120.	75
49120	6185	Presser Foot (hinged) complete for 49111, Nos. 49118, 49119 and 50087F.	3-00
49121	6185	Throat Plate, for double thread, for 49111.	1-50 100
49122	6185	Throat Plate with 665D and 49078, for single thread, for 49111.	2-00
49123	6199	Machine Base Oil Pipe for 49094.	25
49124	6199	" " " " Valve for 49094	40
49125	6184	Feed Dog (double) for 92-1 Machine and 36436.	1-50 80
49126	—	Presser Foot Plate for 49128.	1-00
49127	—	" " Shank for 49128.	75
49128	6184	Presser Foot (hinged) complete for 49125 and 49138, Nos. 49126, 49127 and 50087F.	2-75 100
49129	6184	Throat Plate, for double thread, for 49125.	1-25 100
49130	6184	Throat Plate with 665D and 49078, for single thread, for 49125.	1-75 75
Nos. 49131 TO 49134 FOR 92-1 MACHINE.			
49131	6182	Throat Plate, for double thread, for 49025 and 49103.	1-00
49132	6182	Throat Plate with 665D and 49078, for single thread, for 49025 and 49103.	1-50 65
49133	6183	Throat Plate, for double thread, for 49081.	1-00
49134	6183	Throat Plate with 665D and 49078, for single thread, for 49081.	1-50 60
49135	6176	Arm Rock Shaft.	75
49136	6186	Throat Plate, for double thread, for 49025, for 92-2 Machine.	1-00 75

NUMERICAL LIST OF PARTS

NO.	PLATE	NAME	EACH
49137	6186	Throat Plate with 665D and 49078, for single thread, for 49025, for 92-2 Machine.....	\$1-50 70
49138	6187	Feed Dog, for medium and light bags, for 92-2 Machine and 36436.....	1-50 80
49139	6187	Throat Plate, for double thread, for 49138.....	1-50 00
49140	6187	Throat Plate with 665D and 49078, for single thread, for 49138.....	3-00 75
50069	6203	Crank Connecting Rod Ball Screw Stud, obsolete.....	20
50070c	6192	Looper Bell Crank Pitman Ball Screw Stud (lower).....	15
50070c	6192	Looper Bell Crank Pitman Ball Screw Stud (upper).....	15
50070c	6192	Looper Carrier Pitman Ball Screw Stud (right) for 46242 and 49089.....	15
50083c	6177	Arm Rock Shaft Crank (back) Position Screw for 49007 and 49104.....	05
50083c	6193	Looper Carrier Rock Shaft Crank (back) Set Screw for 49048.....	05
50084c	6177	Arm Rock Shaft Crank (front) Position Screw for 49008.....	04
50084c	6177	Arm Rock Shaft Crank (front) Set Screw for 49008.....	04
50085F	6198	Cloth Plate Screw.....	08
50086c	6181	Feed Regulating Screw Stud.....	22
50087F	6198	Presser Foot Hinge Screw for 49070, 49120 and 49128.....	06
50144	6199	Machine Base Thumb Screw with 49095, for 49094.....	25
50147c	6198	Crank Connecting Rod Hinge Screw.....	20

PLATE 362—ONE-FOURTH SIZE

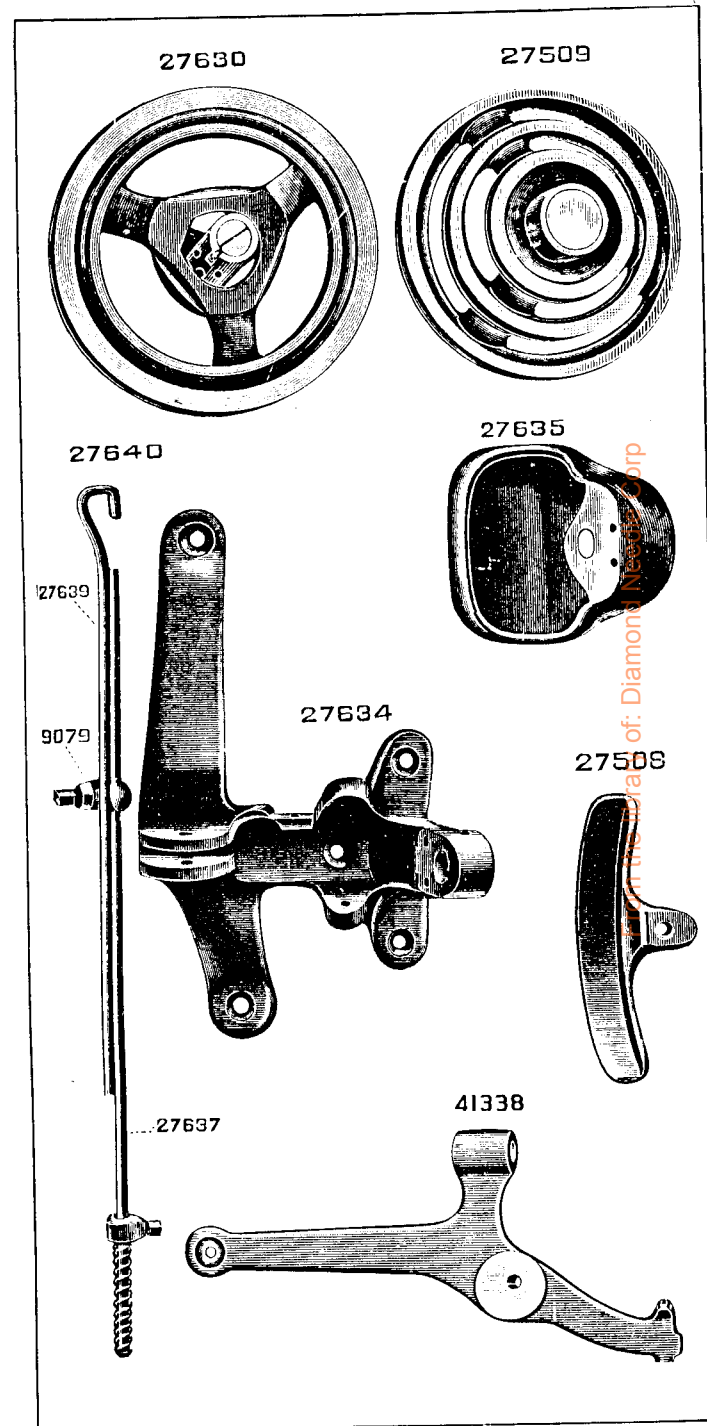

PLATE 363—ONE-FOURTH SIZE

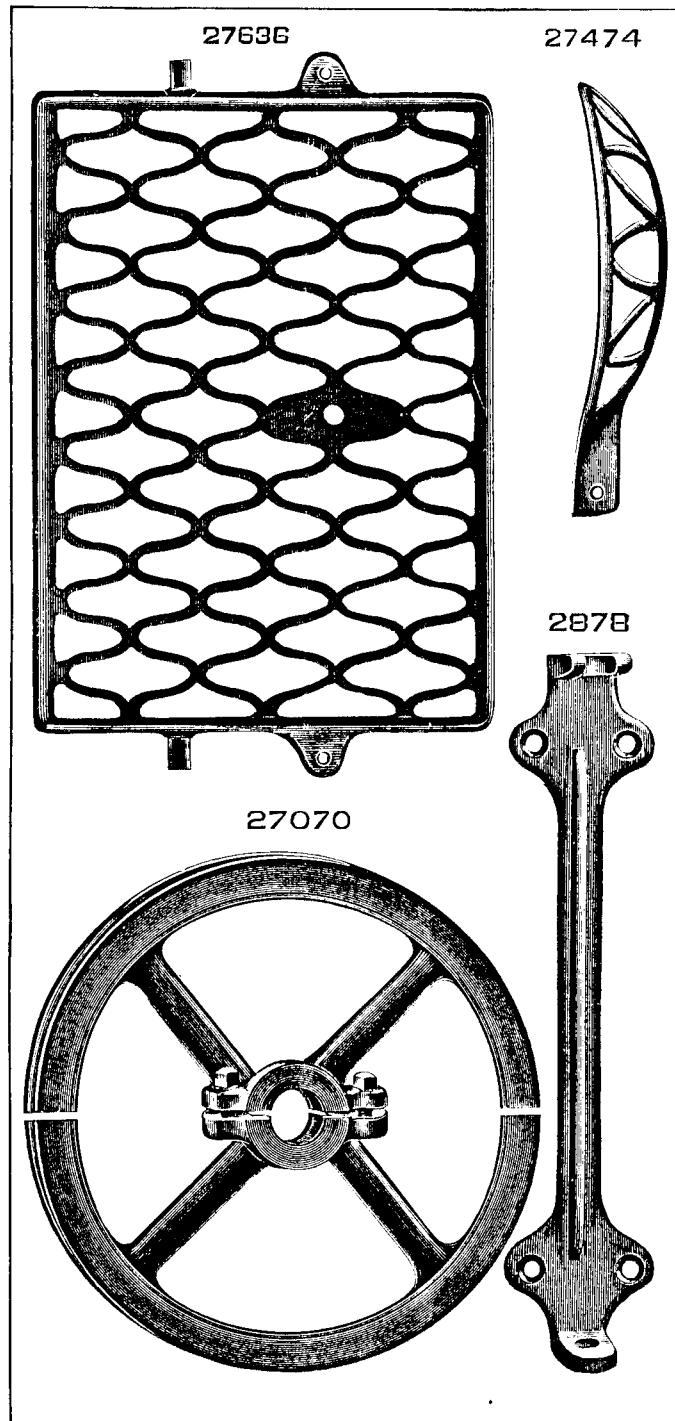

PLATE 1101—FULL SIZE

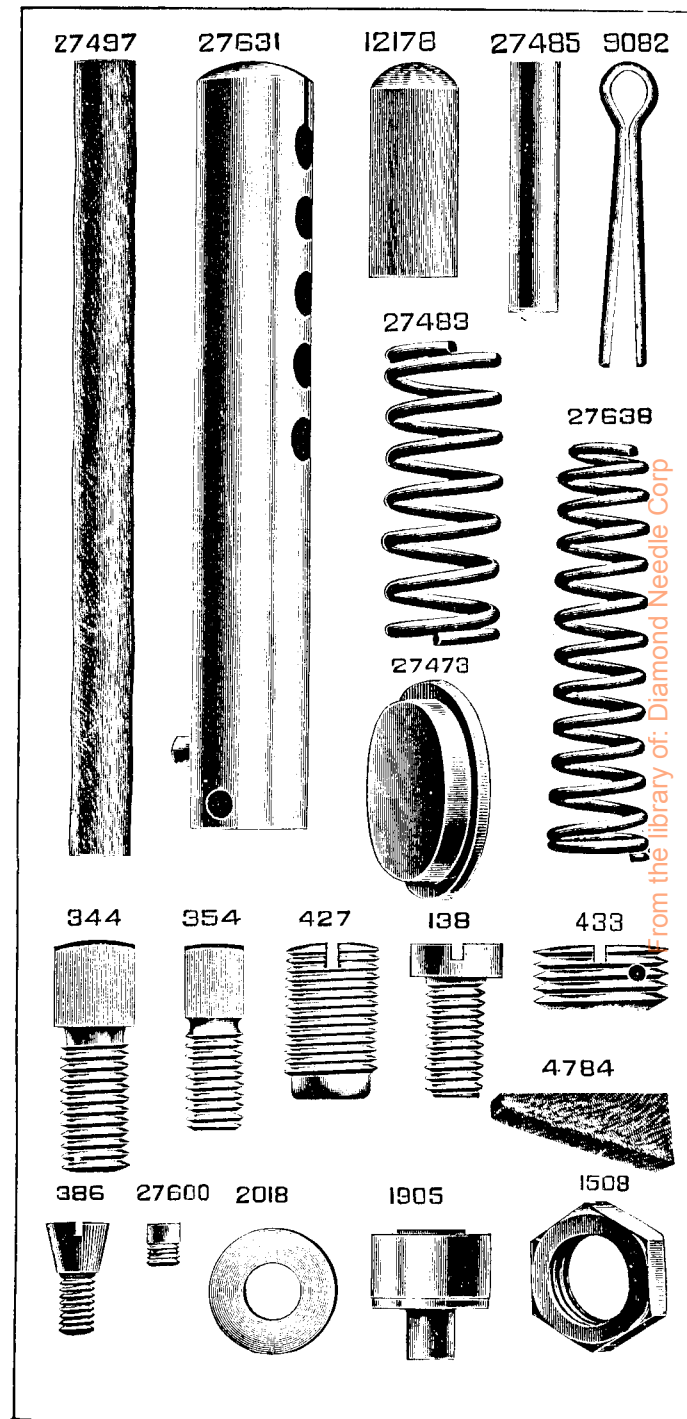

PLATE 2640—ONE-FOURTH SIZE

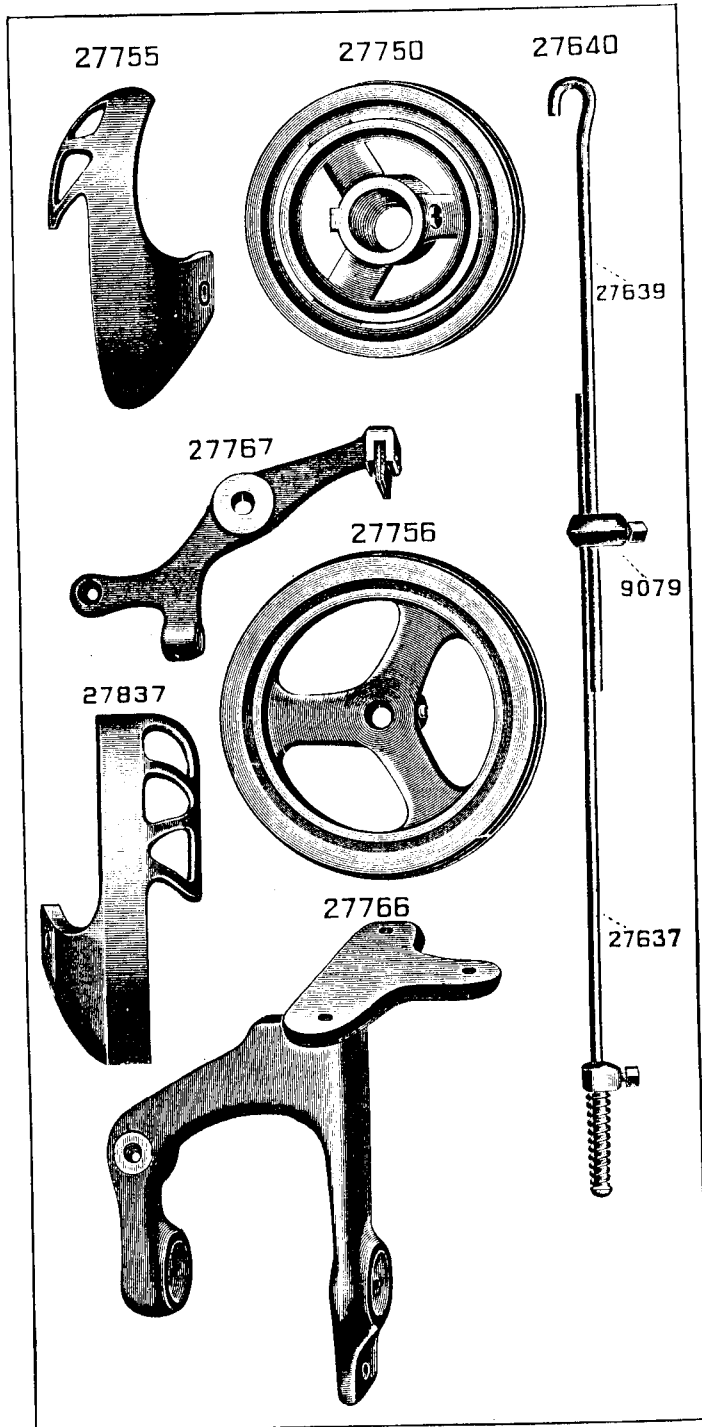
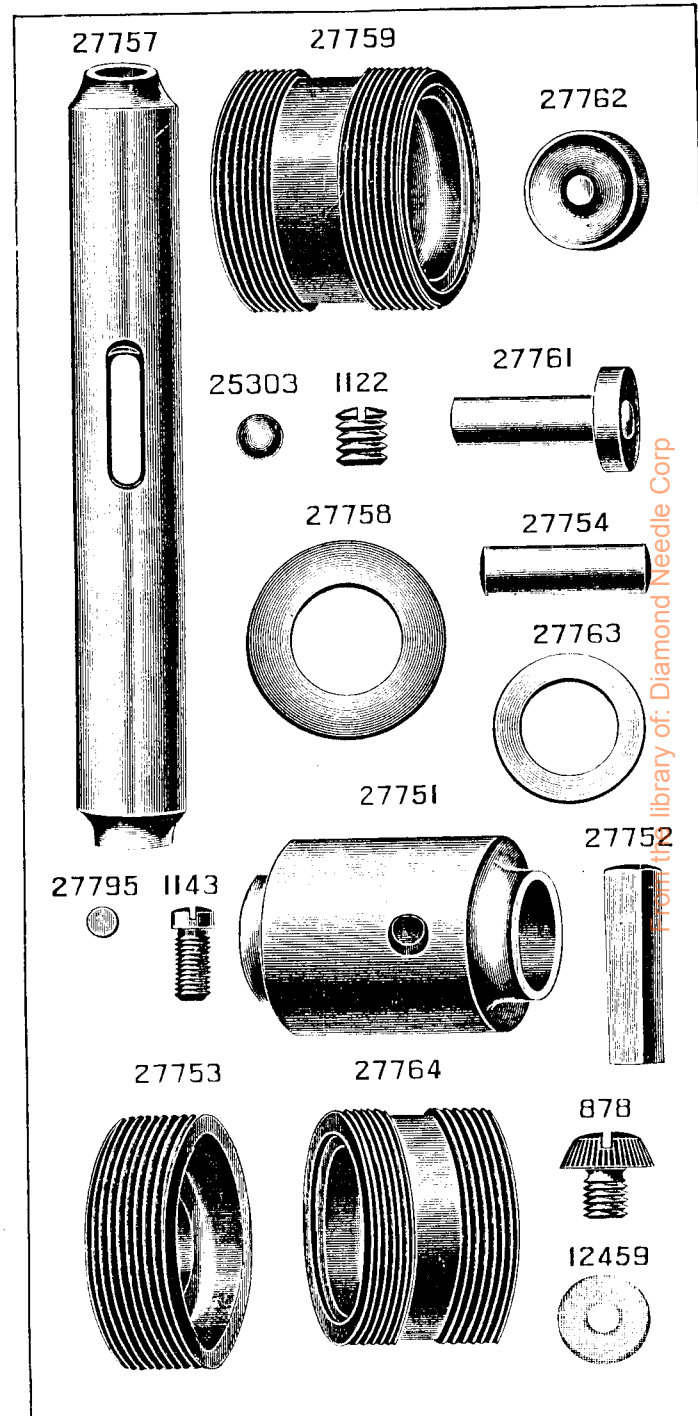

PLATE 2641—FULL SIZE



From the library of: Diamond Needle Corp

PLATE 2642—FULL SIZE

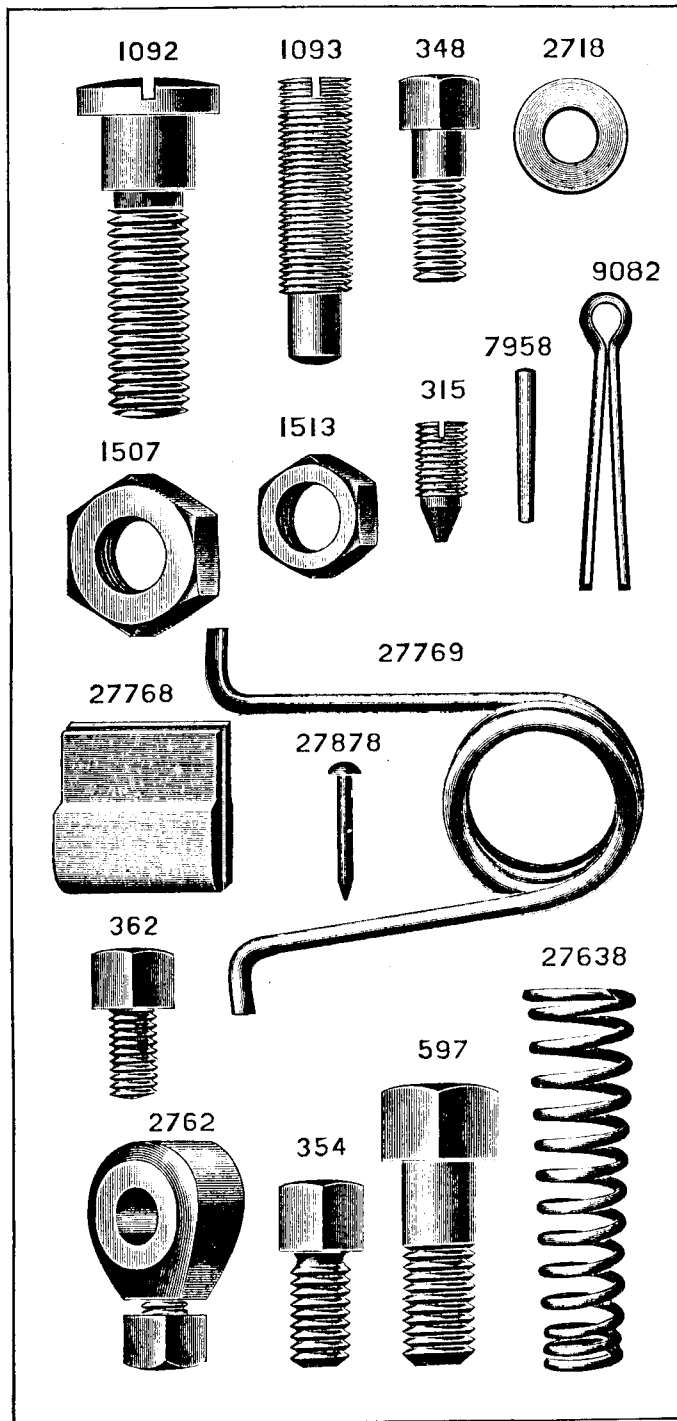

PLATE 2837—ONE-FOURTH SIZE

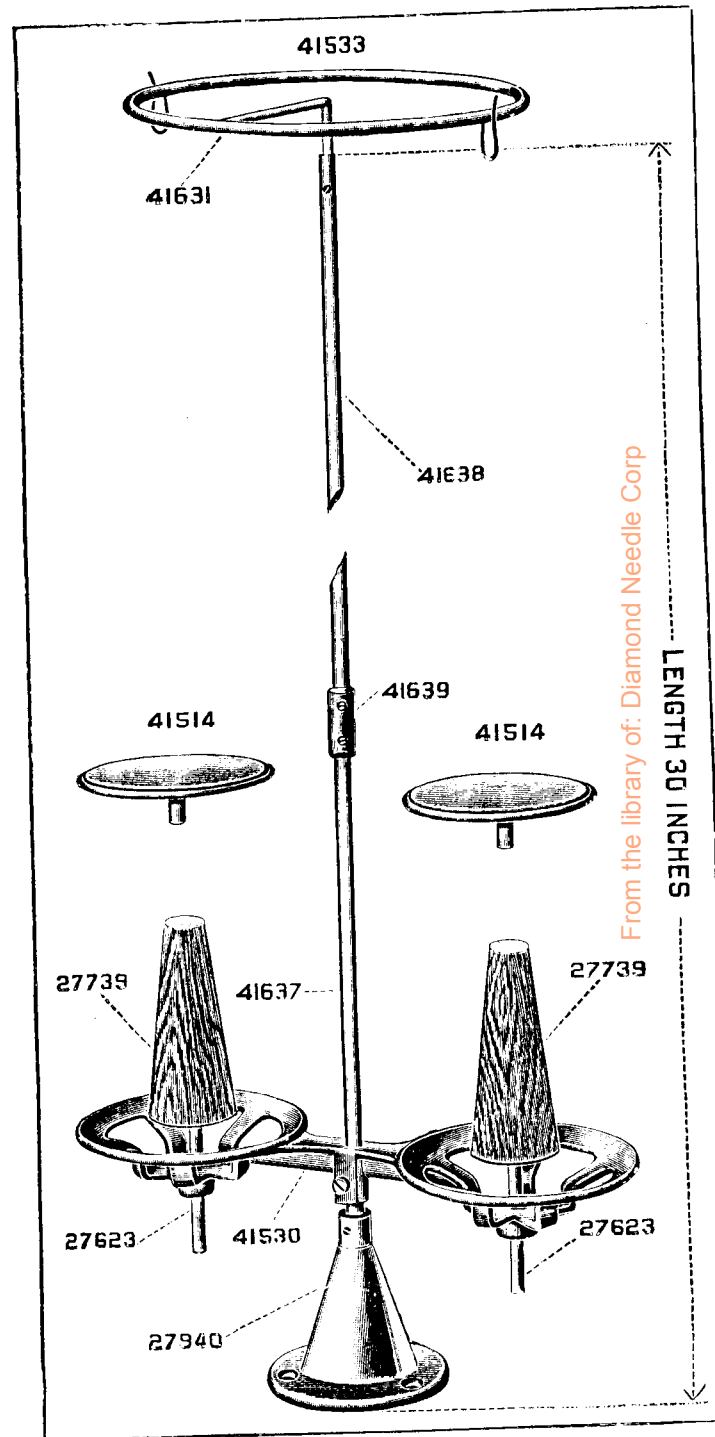

PLATE 6175—ONE-FOURTH SIZE

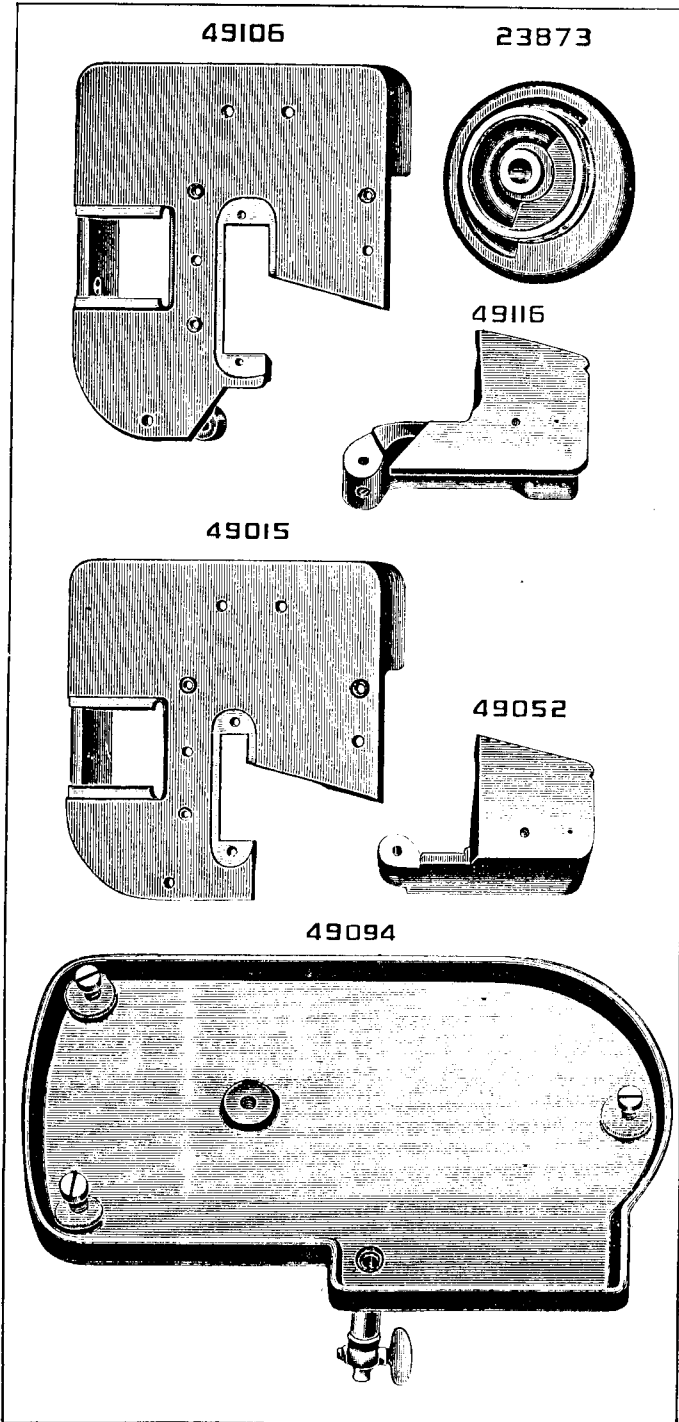

PLATE 6176—ONE-HALF SIZE

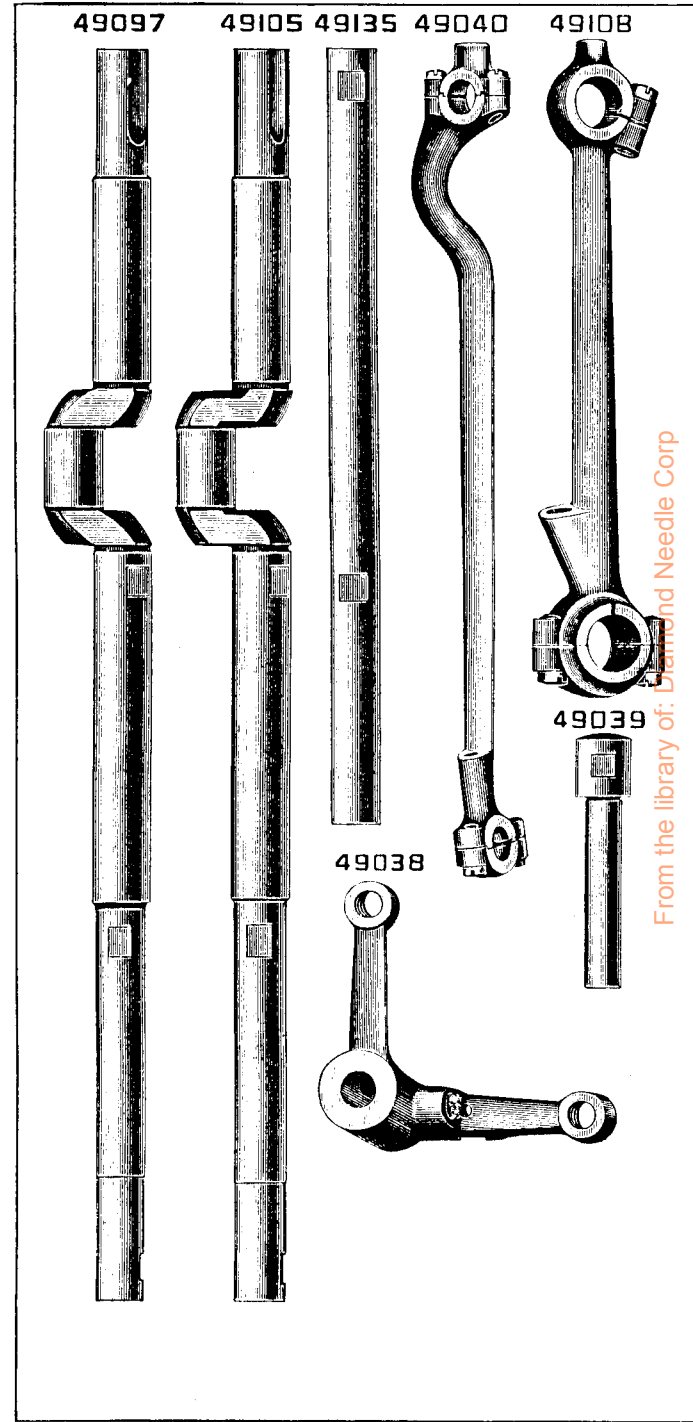

PLATE 6177—FULL SIZE

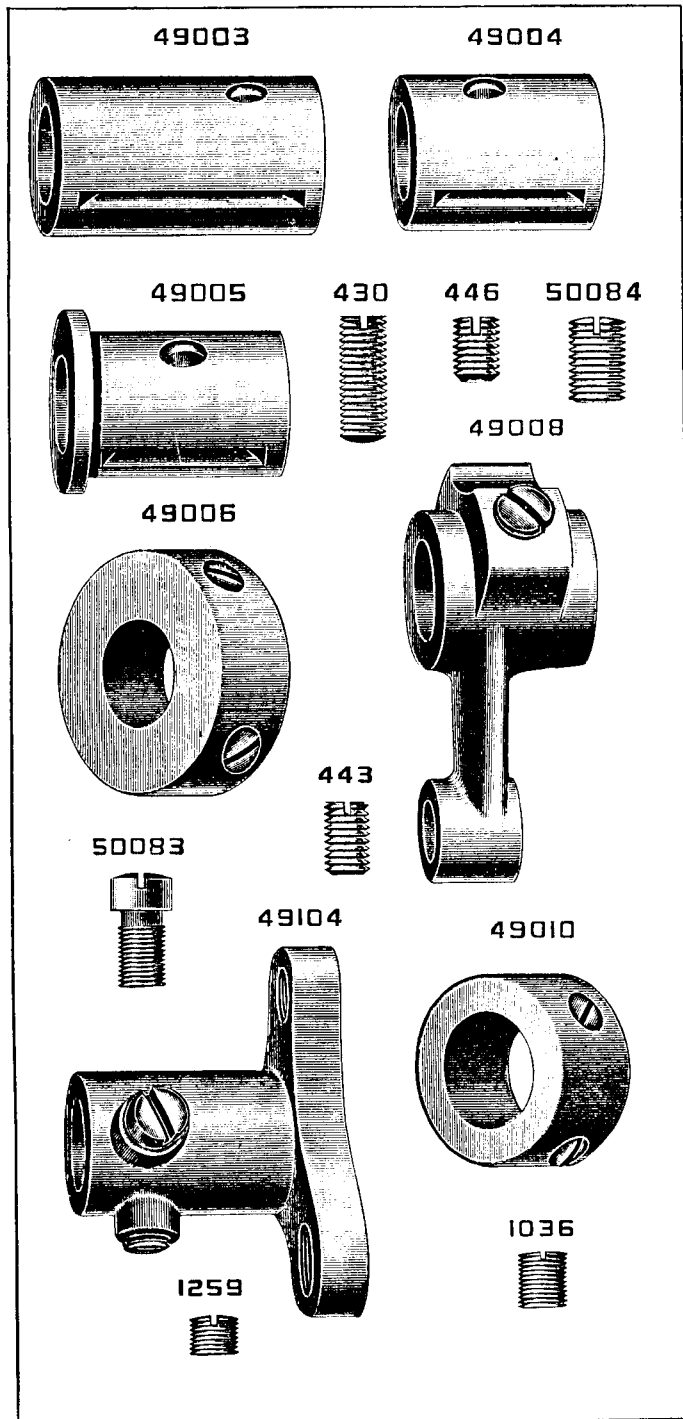
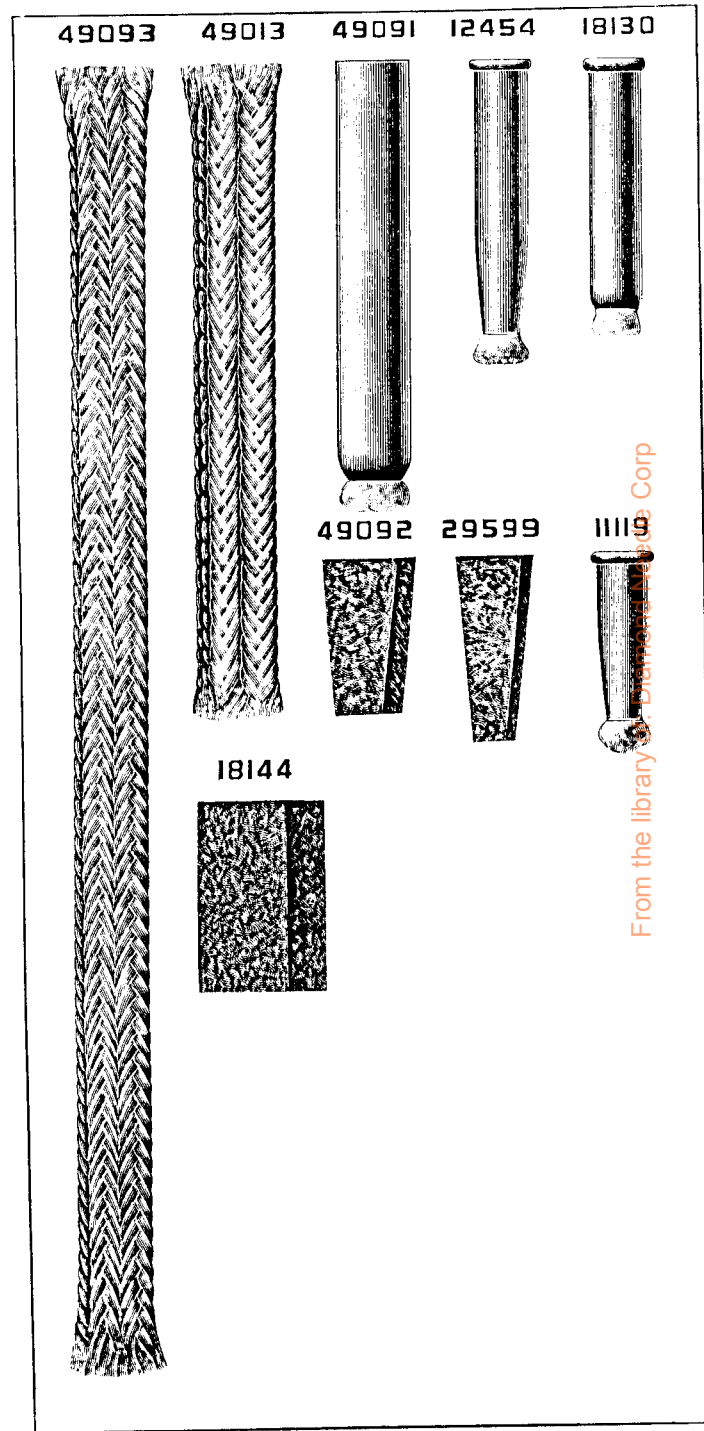

PLATE 6178—FULL SIZE



From the library of www.amsi.org.au

PLATE 6179—ONE-HALF SIZE

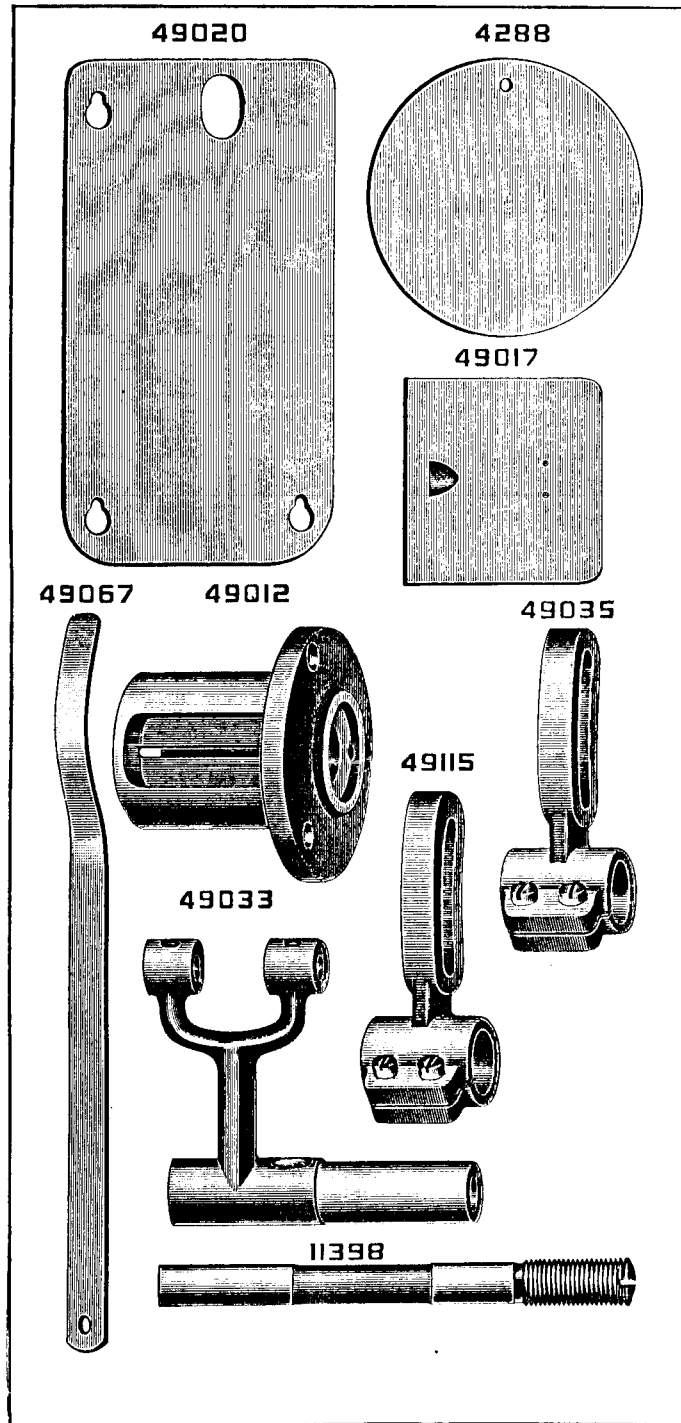
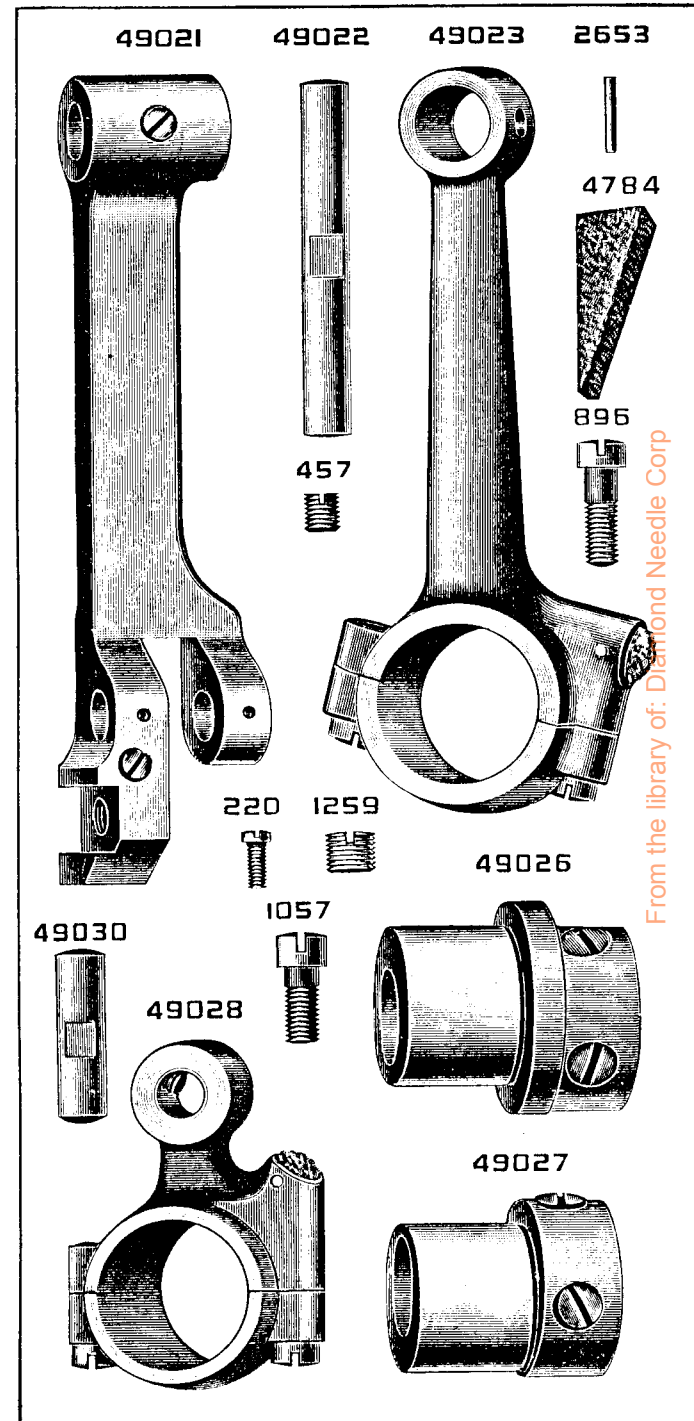

PLATE 6180—FULL SIZE



From the library of: Diamond Needle Corp

PLATE 6181—FULL SIZE

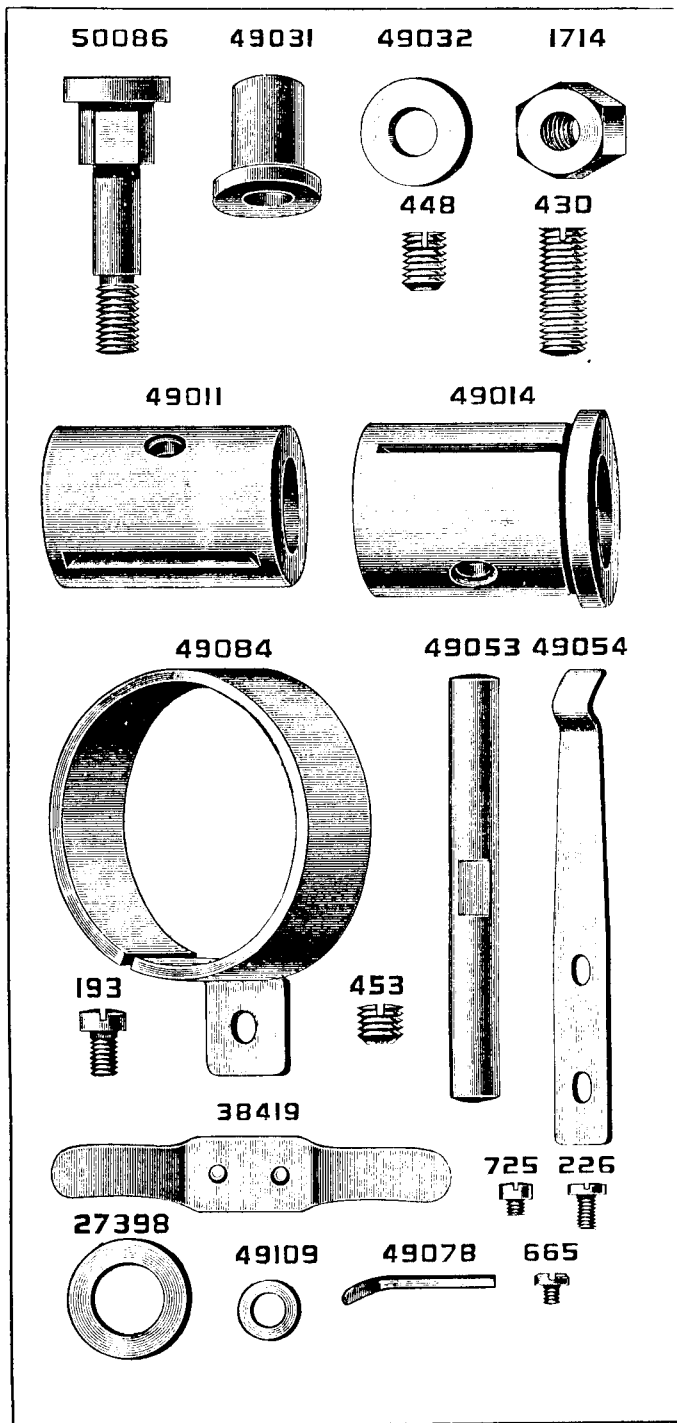
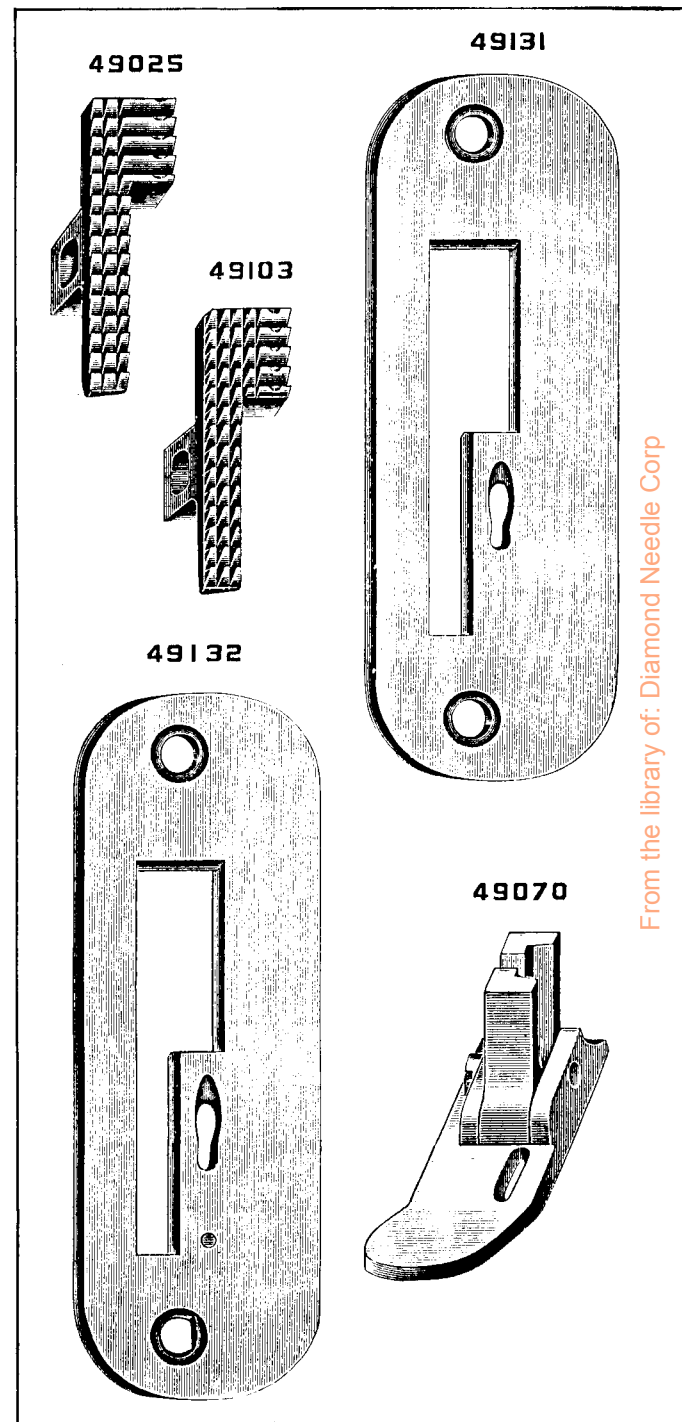

PLATE 6182—FULL SIZE



From the library of: Diamond Needle Corp

PLATE 6185—FULL SIZE

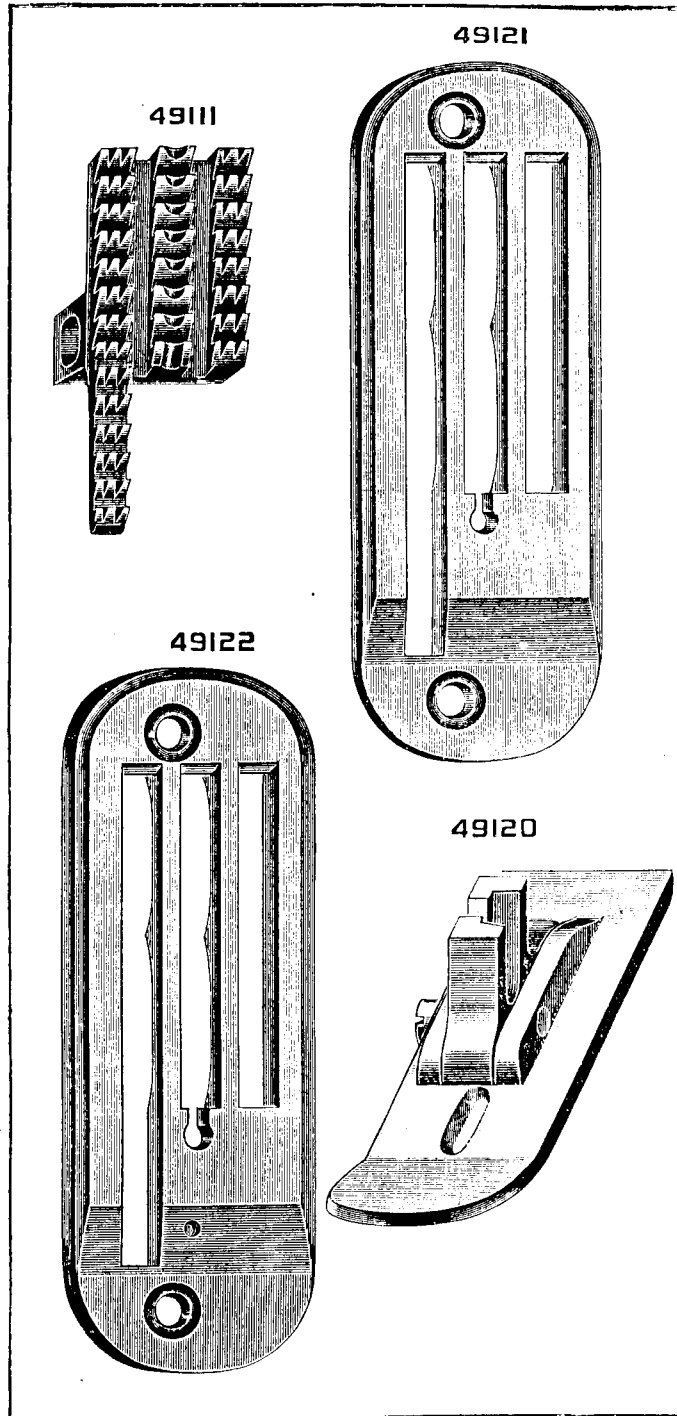

PLATE 6186—FULL SIZE

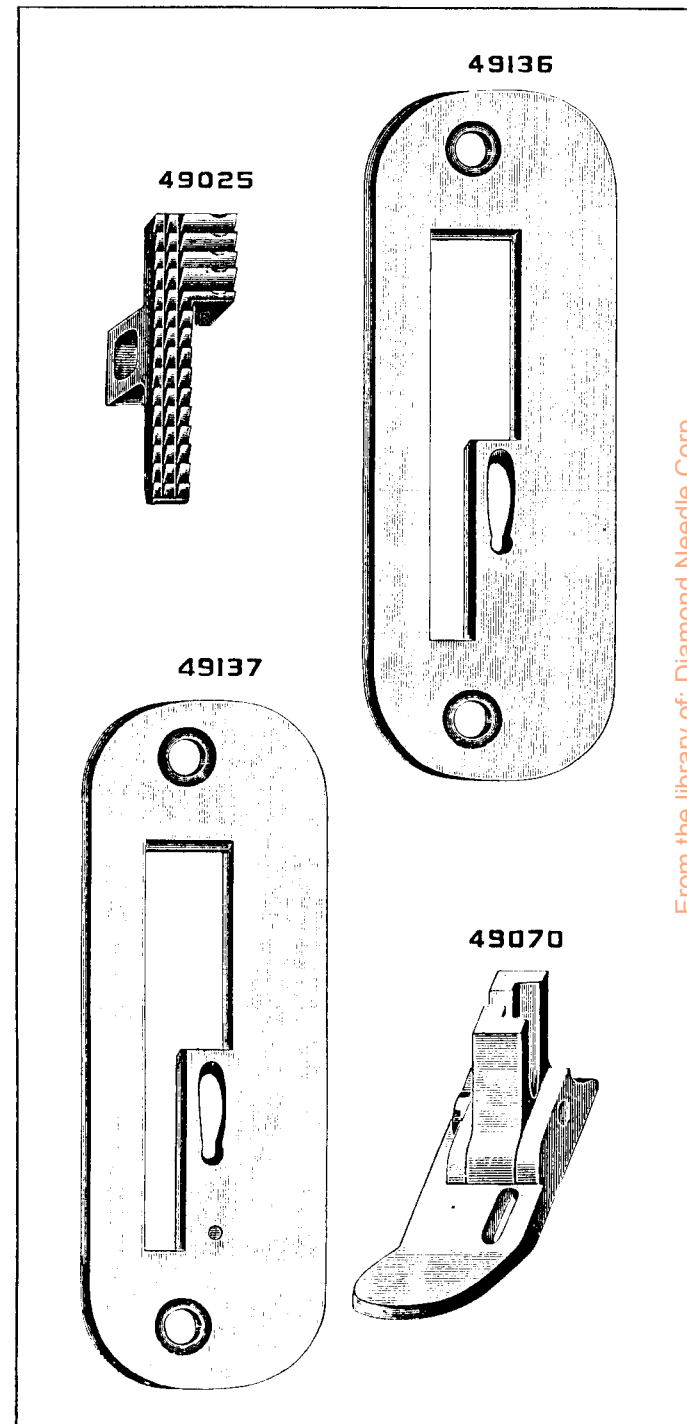

PLATE 6187—FULL SIZE

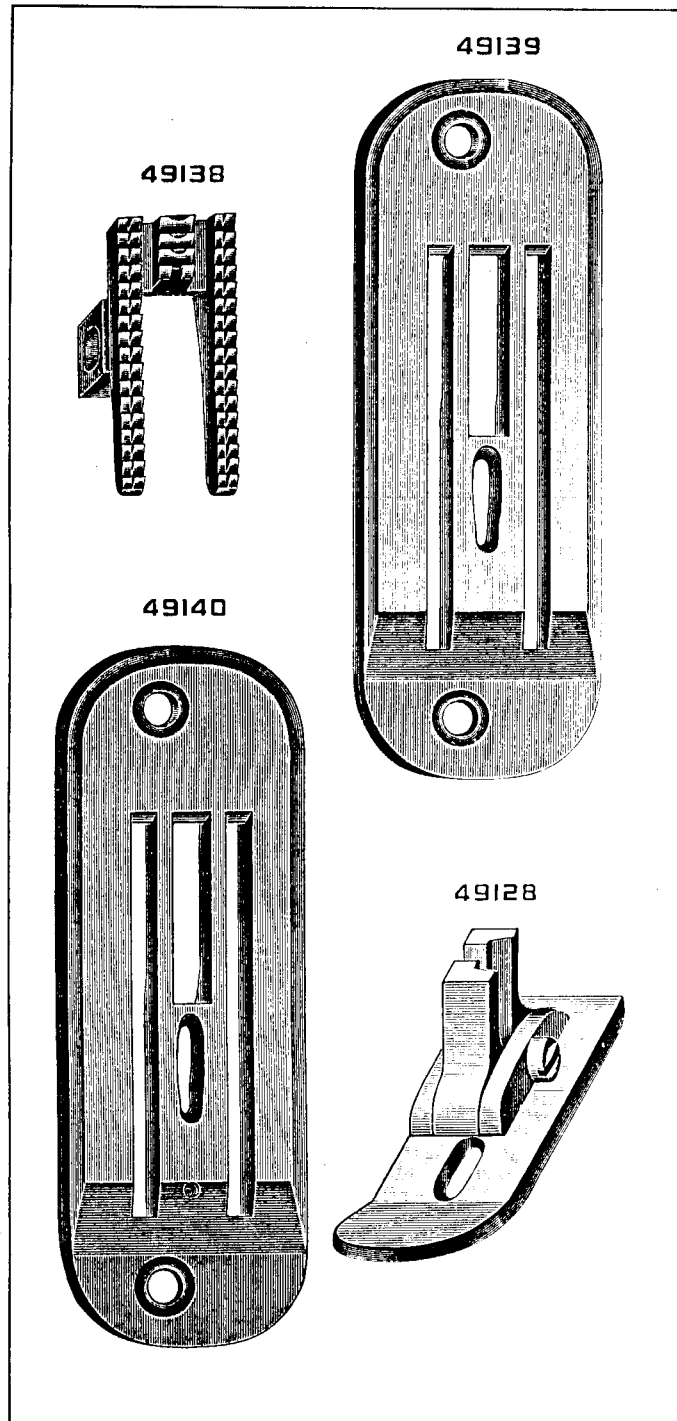
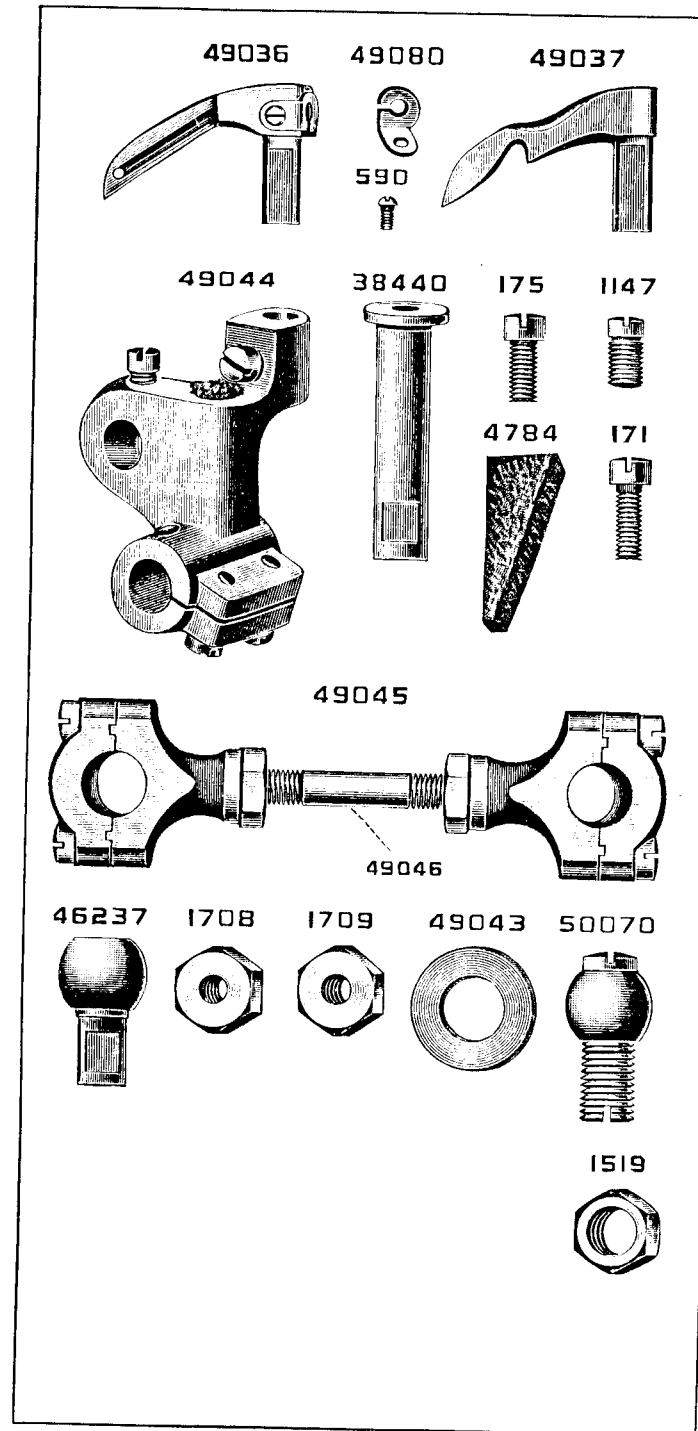

PLATE 6192—FULL SIZE



From the library of: Diamond Needle Corp

PLATE 6193—FULL SIZE

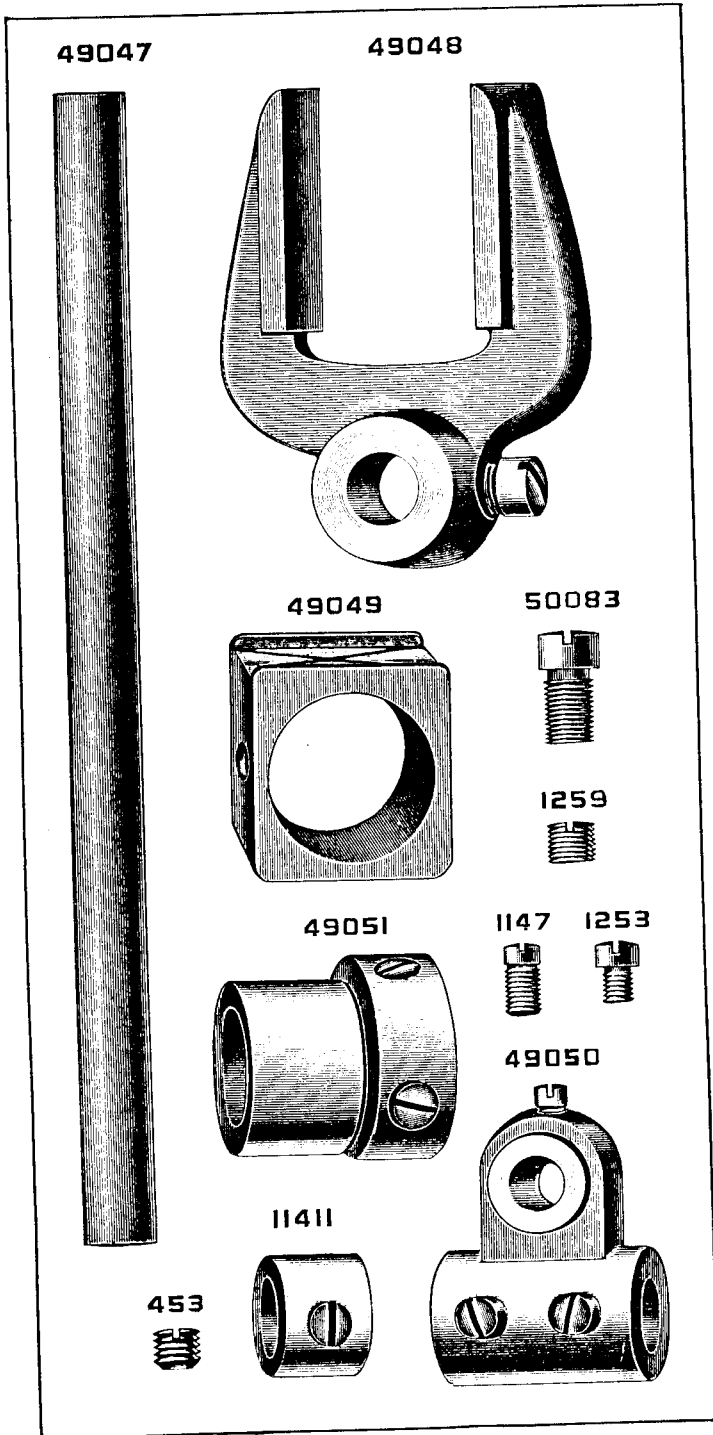
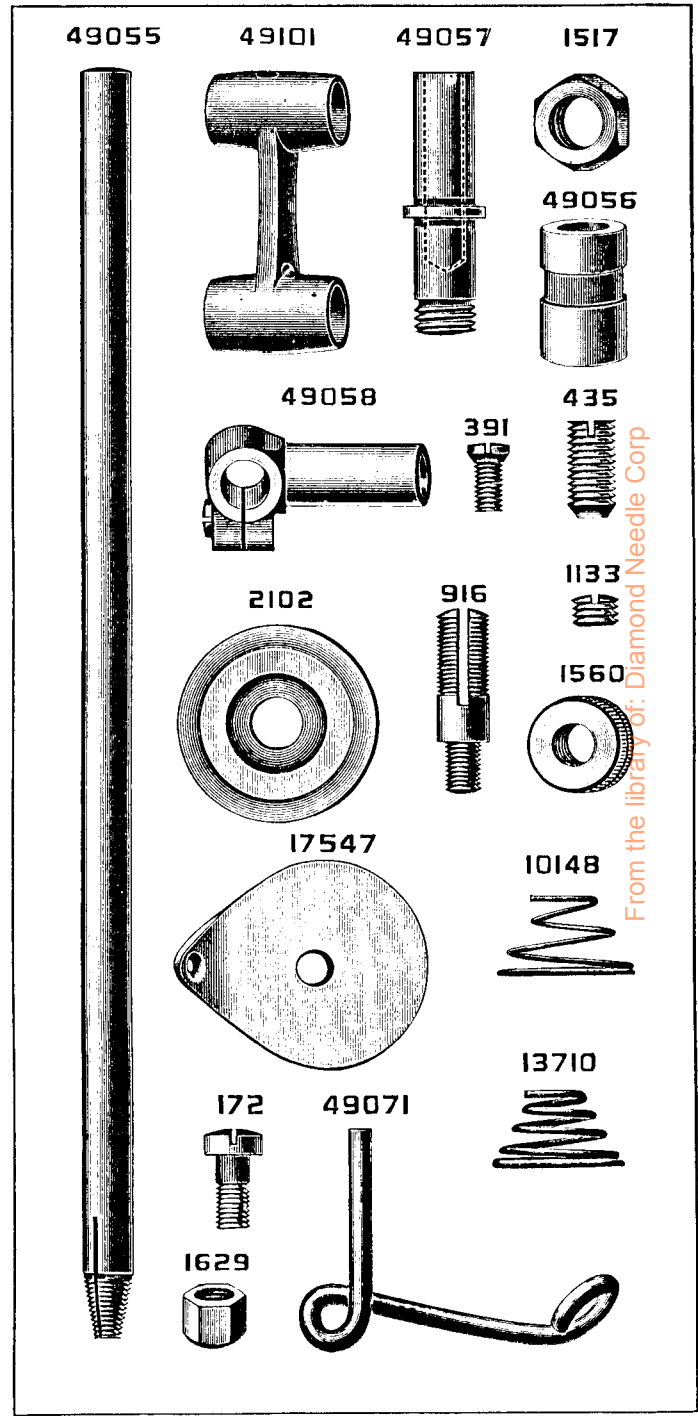

PLATE 6194—FULL SIZE



From the library of: Diamond Needle Corp

PLATE 6195—FULL SIZE

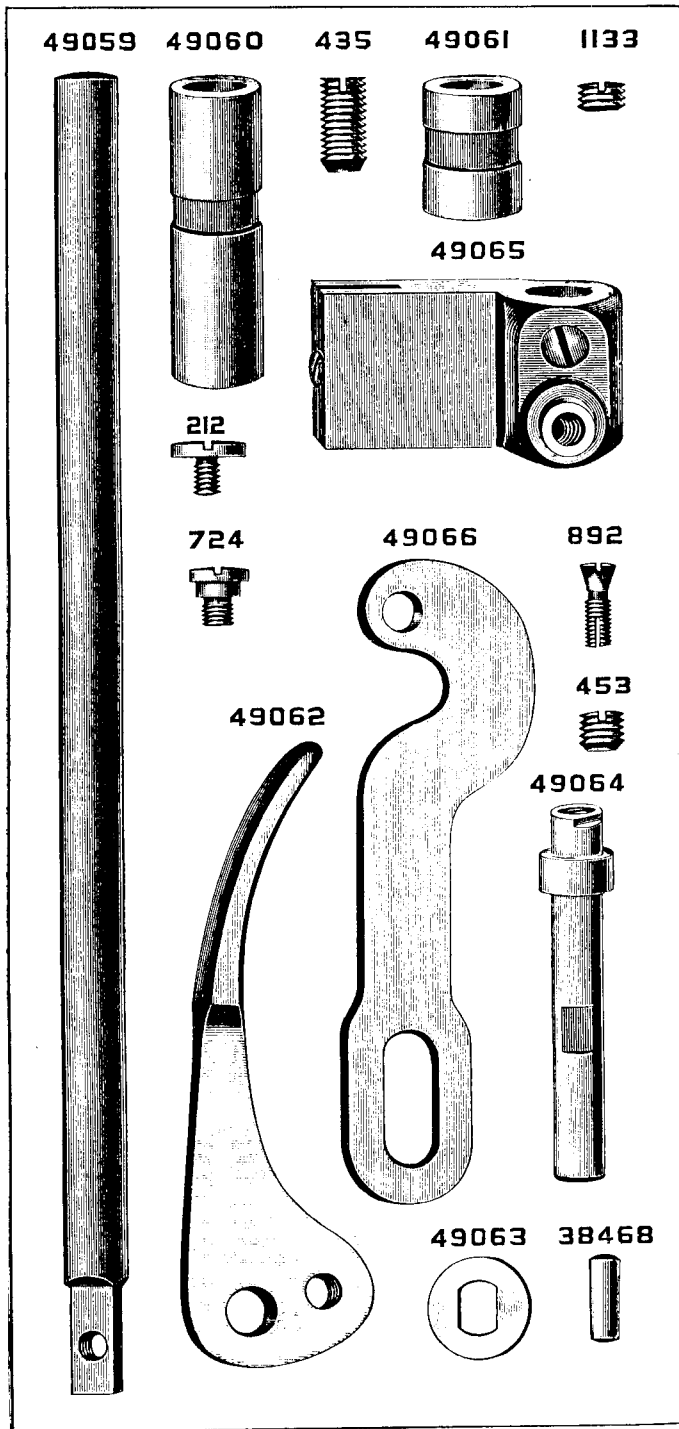
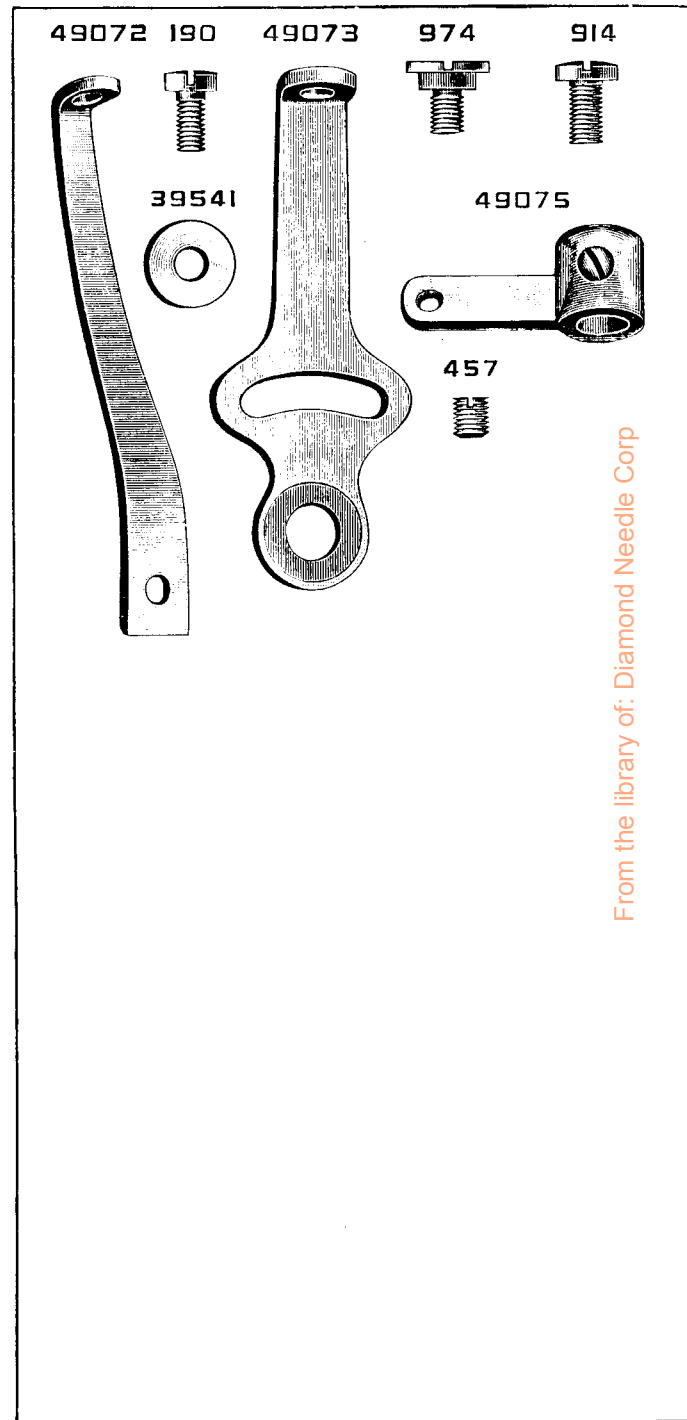

PLATE 6196—FULL SIZE



From the library of: Diamond Needle Corp

PLATE 6197—FULL SIZE

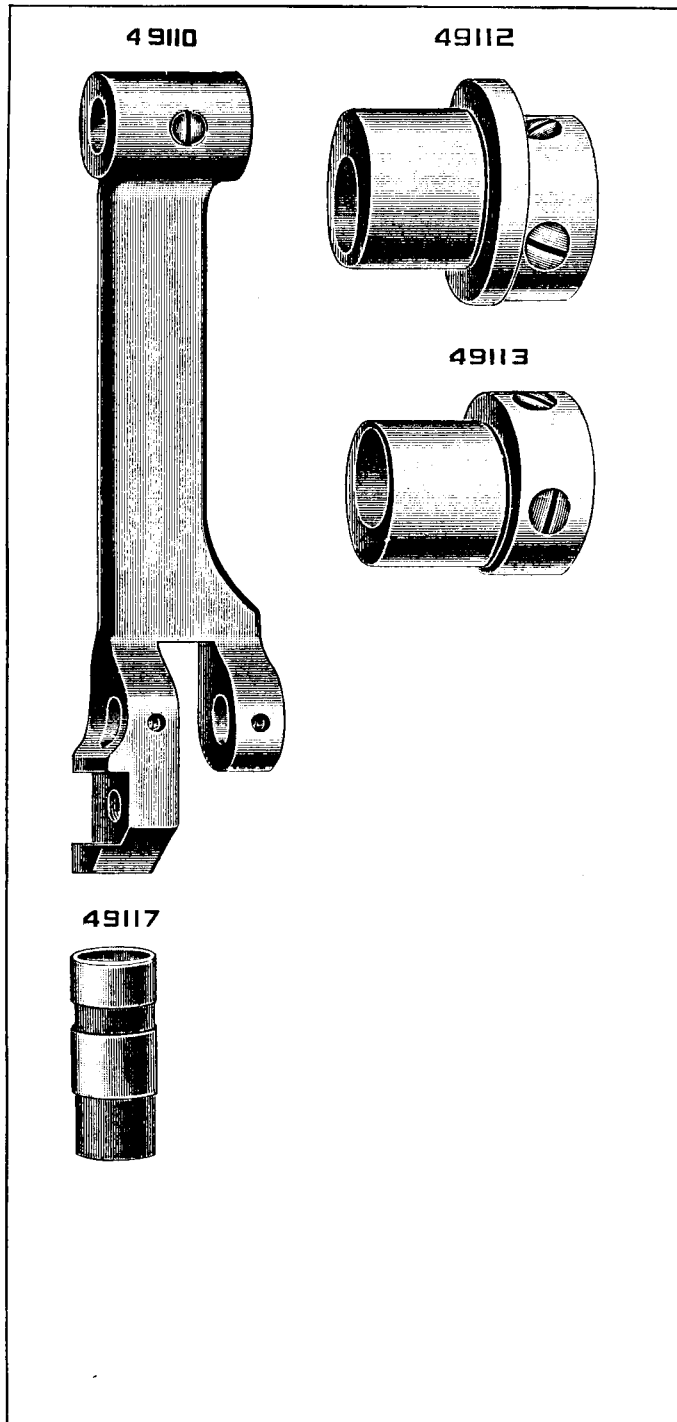

PLATE 6198—FULL SIZE

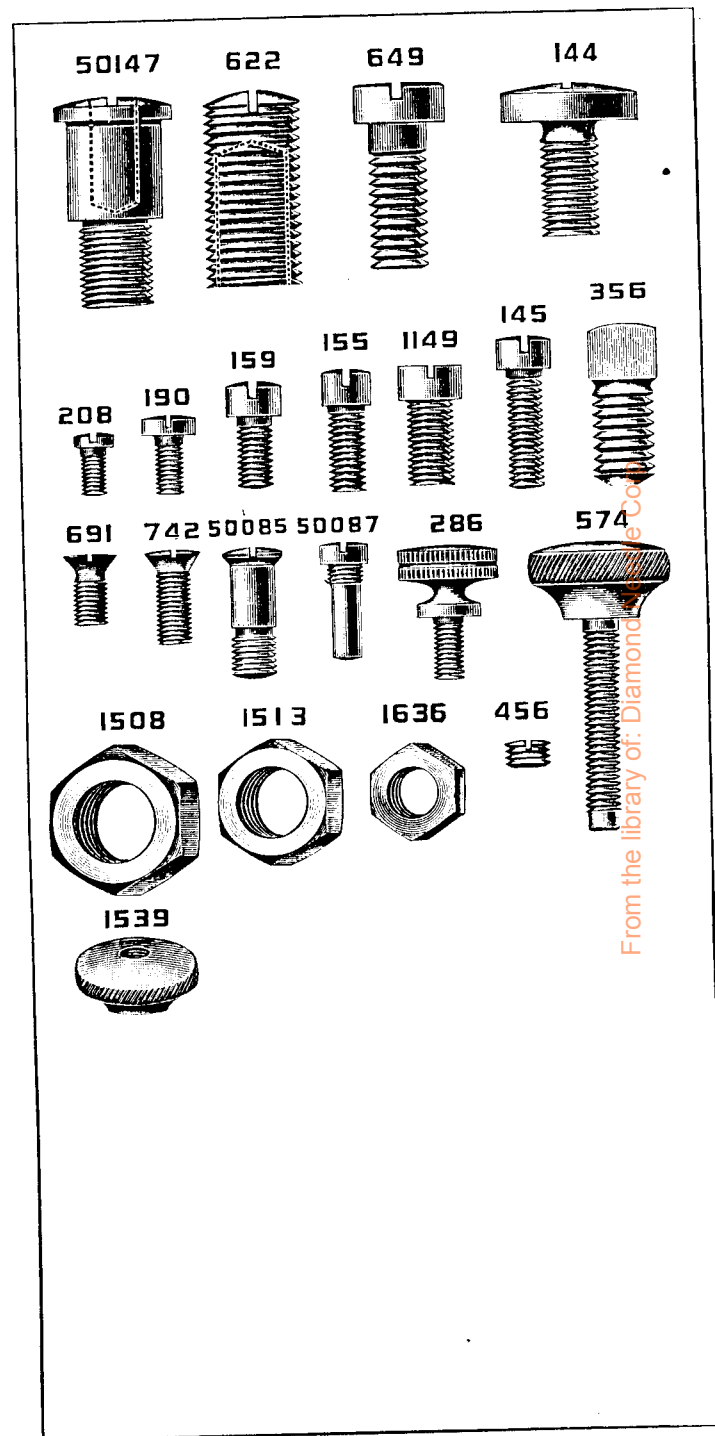

PLATE 6199—FULL SIZE

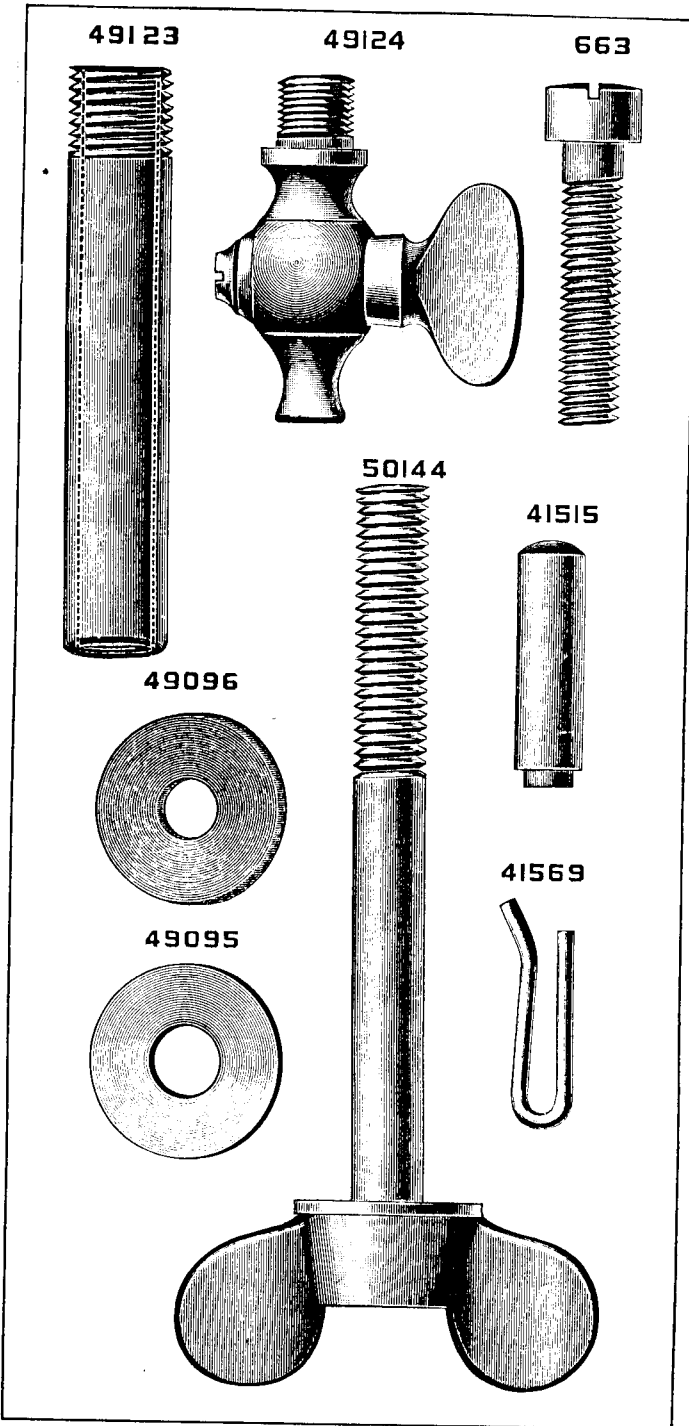
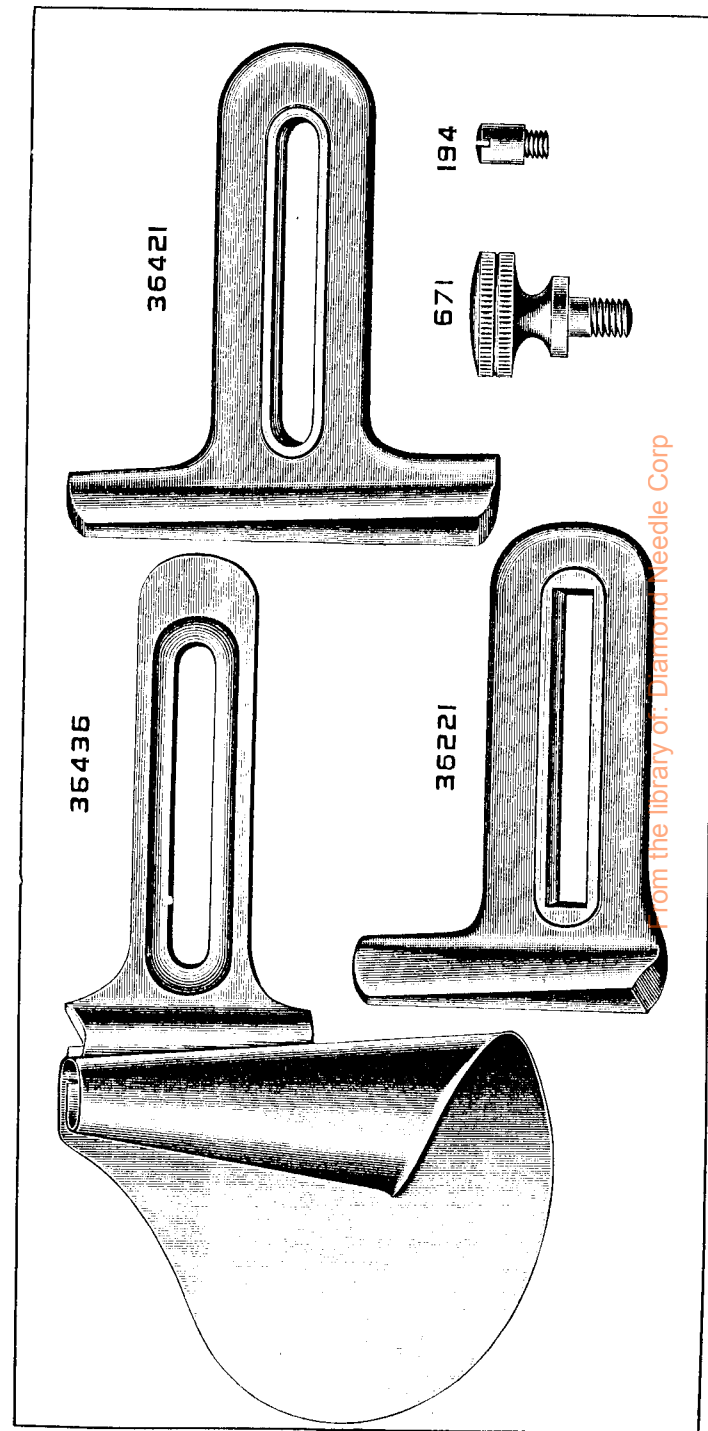

PLATE 6200—FULL SIZE



From the library of: Diamond Needle Corp

PLATE 6201—ONE-HALF SIZE

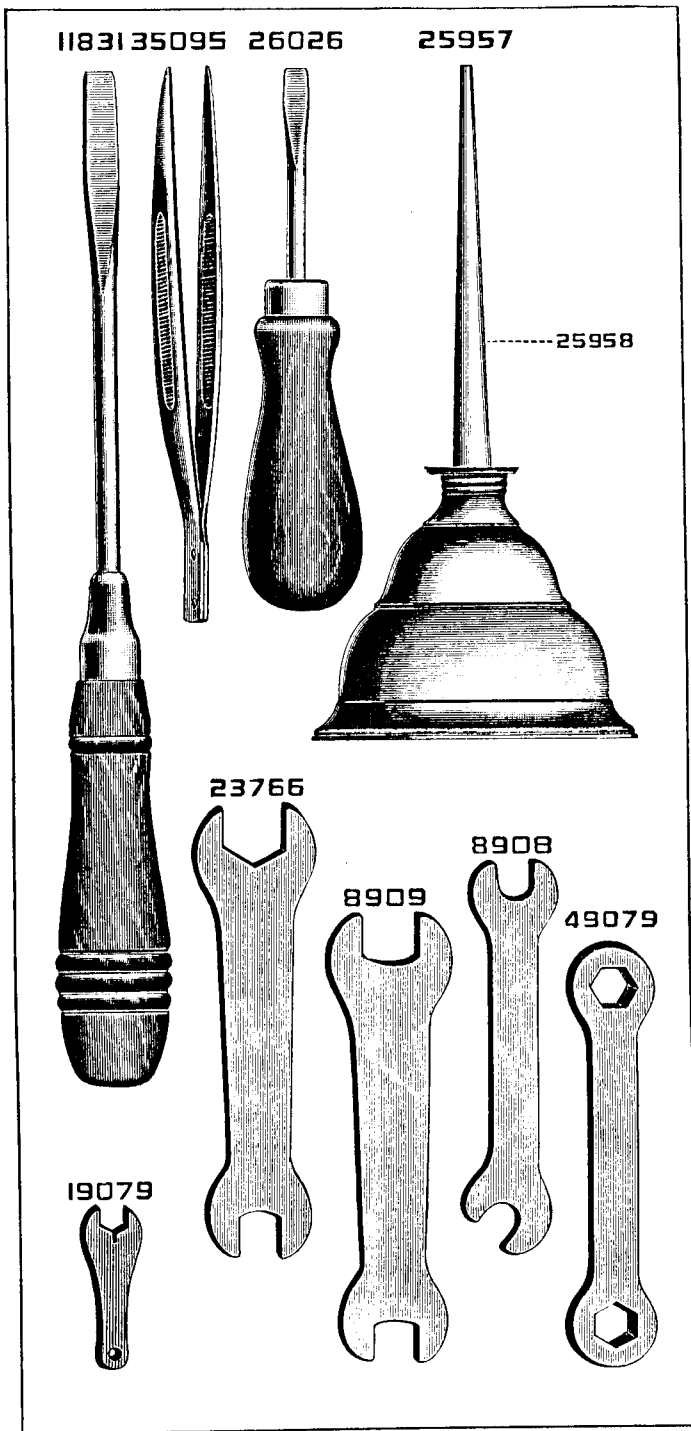
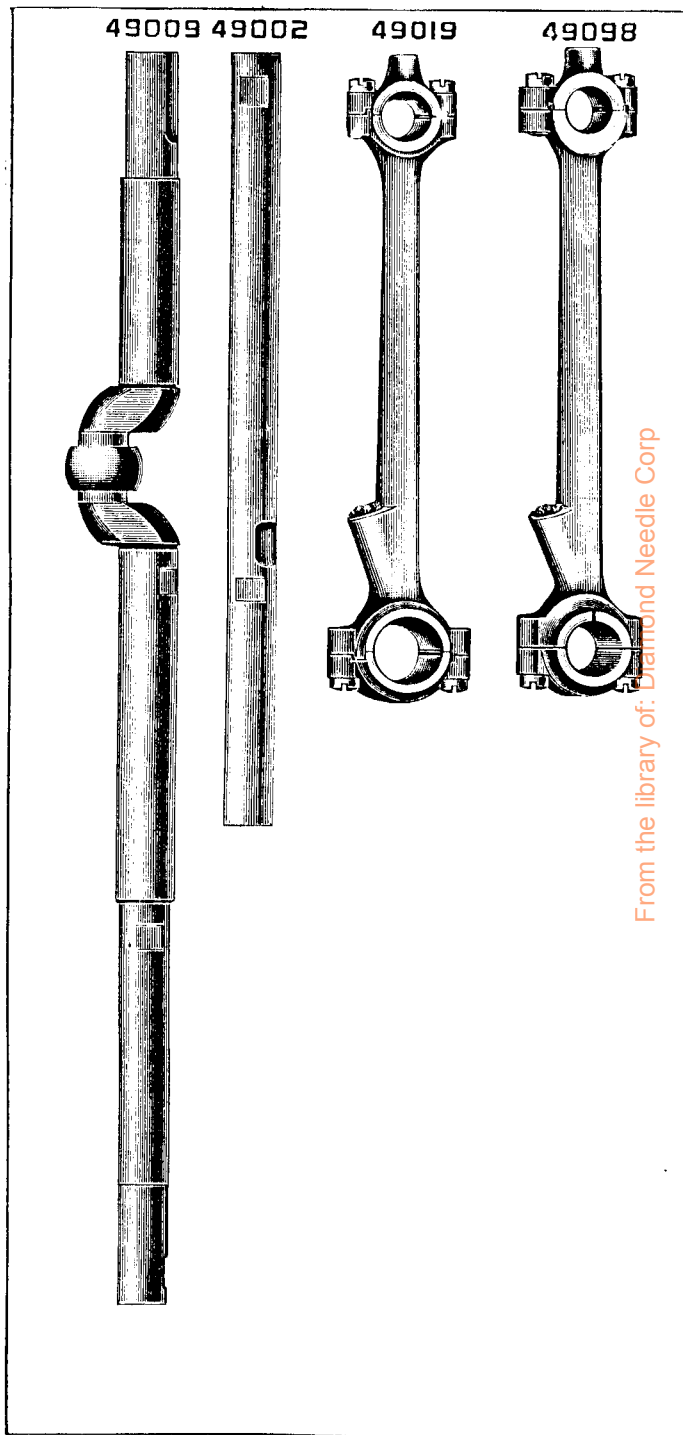

PLATE 6202—ONE-HALF SIZE



From the library of: *Diamond Needle Corp*

PLATE 6203—FULL SIZE

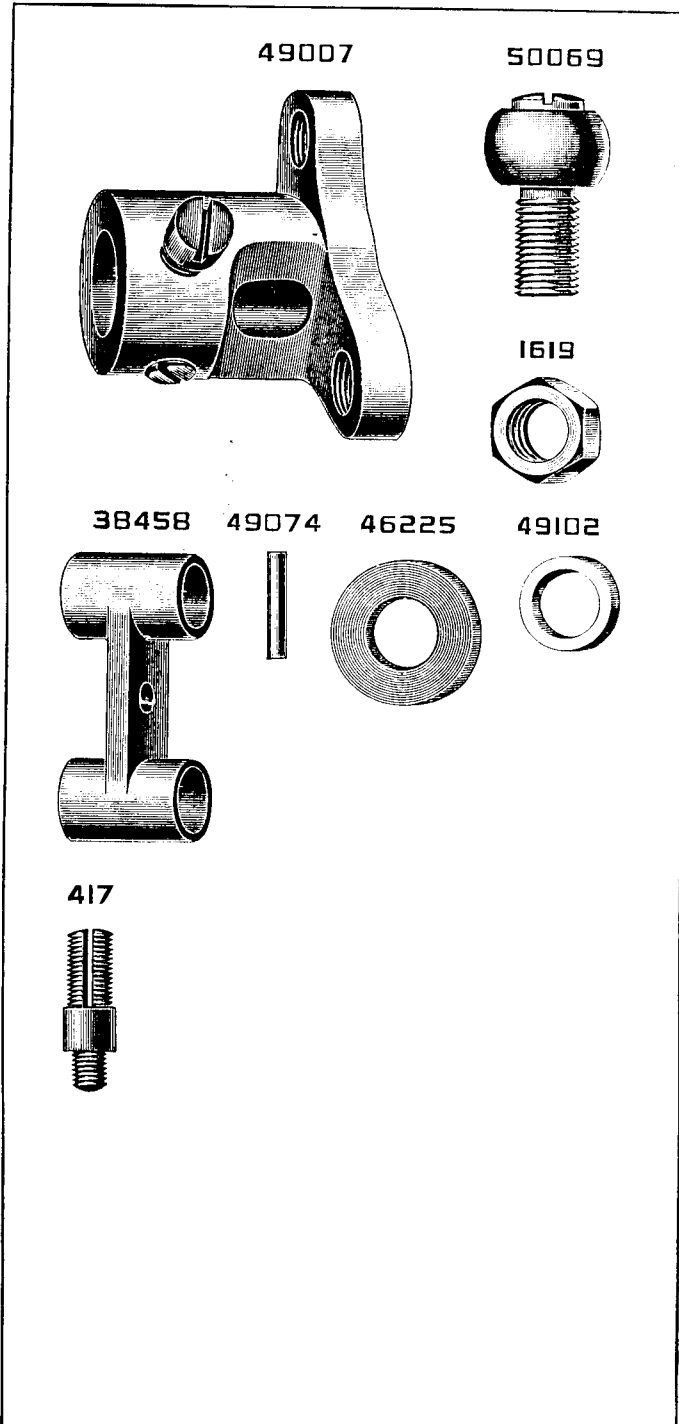
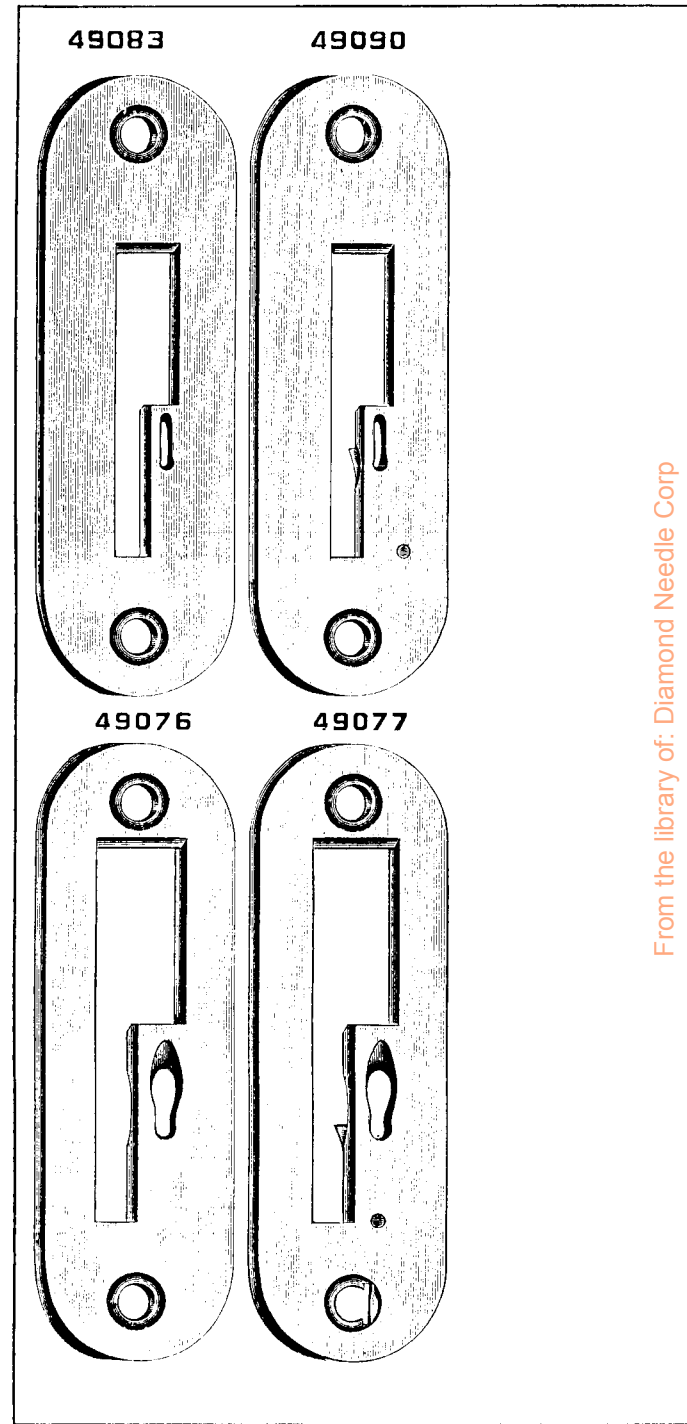

PLATE 6204—FULL SIZE



From the library of: Diamond Needle Corp